



# Atlas Workholding Finger Power Chuck

## DF 6" - 18" Chucks

- ☑ 2 and 3 jaw clamping chucks
- ☑ Finger rotates and pulls down
- ☑ Eliminates part distortion or damage caused by conventional O. D. and I. D. gripping

Model No.	Jaw's Compensation	Sleeve Stroke	Gripping Capacity Bar		Draw Force Pull lb/f	Grip Max. lb/f	Wt. RPM	lbs
			Max.	Min.				
DF6-A4	.078	.551	2.913	1.181	3,950	3,100	3600	20
DF6-A5	.078	.551	2.913	1.181	3,950	3,100	3600	20
DF6-A6	.078	.551	2.913	1.181	3,950	3,100	3600	20
DF8-A5	.078	.591	4.331	1.969	3,750	4,630	2900	40
DF8-A6	.078	.591	4.331	1.969	3,750	4,630	2900	40
DF10-A6	.078	.787	5.748	2.362	7,950	6,150	2400	66
DF10-A8	.078	.787	5.748	2.362	7,950	6,150	2400	66
DF12-A8	.078	.787	7.717	4.331	7,950	6,150	2100	90
DF12-A11	.078	.787	7.717	4.331	7,950	6,150	2100	90
DF15-A8	.078	.984	10.236	7.087	9,900	7,950	1800	161
DF15-A11	.078	.984	10.236	7.087	9,900	7,950	1800	161
DF18-A8	.078	.984	13.150	4.465	9,900	7,950	1600	225
DF18-A11	.078	.984	13.150	4.465	9,900	7,950	1600	225

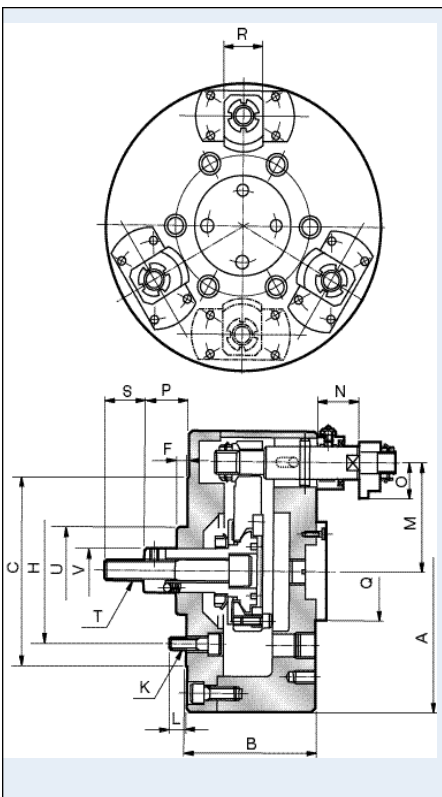

### Dimensional Data

MODEL	DF-6	DF-8	DF-10	DF-12	DF-15	DF-18
A	6.50	8.25	10	12	15	17.72
B	2.95	3.54	4.13	4.13	4.72	5.12
C	5.512	6.693	8.661	8.661	11.811	11.811
F	.315	.315	.315	.315	.315	.315
H	4.125	5.250	6.750	6.750	9.250	9.250
K	3-M10	3-M12	3-M16	3-M16	3-M20	3-M20
L	.630	.748	.906	.906	1.260	1.260
M	2.165	2.953	3.740	4.724	6.102	7.560
N max.	2.126	2.323	2.835	2.835	3.307	3.307
N min	1.181	1.378	1.575	1.772	1.969	1.969
O	1.575	1.969	2.560	2.560	3.346	3.346
P max.	1.732	1.969	2.362	2.362	2.953	2.953
P min	1.181	1.378	1.575	1.575	1.969	1.969
Q	1.772	2.560	3.346	4.331	5.512	6.890
R	.945	1.063	1.260	1.260	1.417	1.417
S	1.417	1.417	1.811	1.811	1.969	1.969
T	M16x2.0	M20x2.5	M24x3.0	M24x3.0	M27x3.0	M27x3.0
U	1.654	1.969	2.126	2.126	2.835	2.835
V	1.256	1.496	1.732	1.732	2.047	2.047

All dimensions of the 2-jaw and 3-jaw are the same

HOW TO ORDER: State quantity, Model Number of chuck and shipping instructions.