

SAFETY DRILL VISE

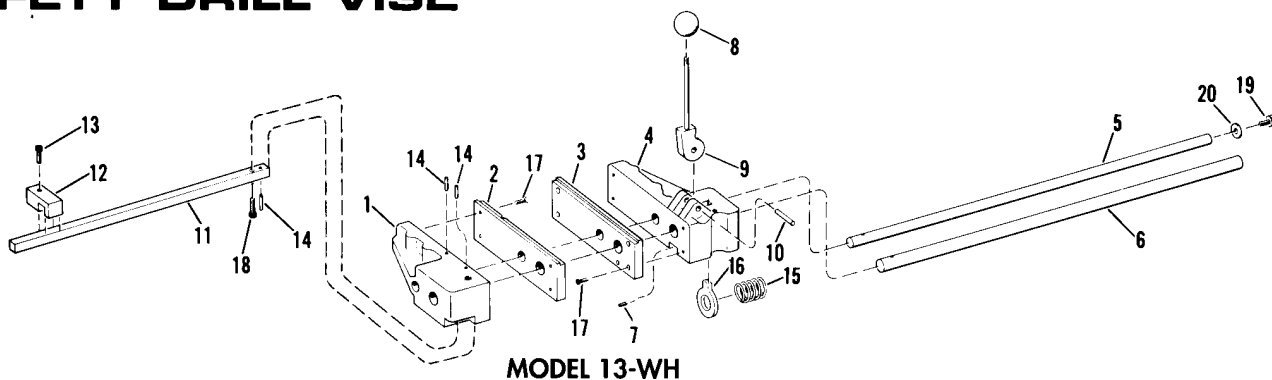

MODEL 13-WH

Index No.	Part Name	Part No.	Price
1	Stationary Jaw Casting (Note 1)	13WH-1	--
2 & 3	False Jaws (Set of 2)	13WH-2 & 3	\$23.54/pair
4	Movable Jaw Casting (Note 1)	12WH-4	--
5	Guide Bar	12WH-5	4.56
6	Locking Bar	12WH-6	18.48
7	1/4-20 x 3/4 Screw	12WH-8	0.54
7A	1/4-20 x 1/2 Screw	12WH-8A	0.54
8	Knob -- 3/8-24 thread	SV-6821	2.03
9	Handle Lever Assembly	12WH-11	11.77
10	5/16 x 1 1/8 Rollpin	12WH-12	0.68
11	Mounting Bar	13WH-13	11.09
12	Mounting Block	13WH-14	10.00
13	3/8-1 6 x 1 1/2 Screw	13WH-15	0.94
14	3/16 x 1 1/8 Rollpin (3 required)	2316-A	0.35
15	Spring	PA-6817	1.77
16	Locking Ring	SV-6816	13.55
17	1/4-20 x 1/2 Screw (8 required)	30-1/2	0.54
18	1/4-20 x 7/8 Screw	305-8	0.54
19	5/16-24 x 1/2 Screw	H-14	0.59
20	1/4" USS Washer	305-26	0.24

Note 1. Prices not shown, as replacement jaw castings are not available.

SEE OPERATION AND MAINTENANCE INSTRUCTIONS FOR GRIP-MASTER VISES ON THE GRIP-MASTER VISES PAGE.
WHEN ORDERING PARTS, INDICATE PART NUMBER, MODEL NUMBER AND PRICE.

DRILL PRESS VISE (Table on next page)

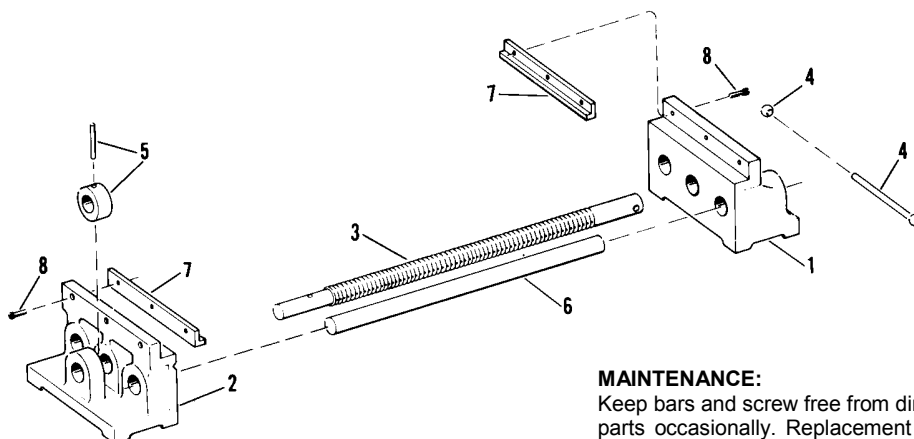

MAINTENANCE:

Keep bars and screw free from dirt and chips. Oil moving parts occasionally. Replacement parts are available for immediate shipment from factory stock, or you may order through your local Heinrich distributor.

Index No.	Part Name	MODEL NUMBER					
		10		20		30	
		Part No.	Price	Part No.	Price	Part No.	Price
1	Movable Jaw Casting (Note 1)	10A	--	20A	--	30A	--
2	Stationary Jaw Casting (Note 1)	10B	--	20B	--	30B	--
3	Screw	1013	\$10.59	2313	\$23.10	2313	\$23.10
4	Handle, with Two Buttons	1015	2.35	2315	3.53	2315	3.53
5	Collar, with Rollpin	1016	2.94	2316	4.71	2316	4.71
6	Guide Bar	1014	2.46	2014	6.65	814	12.32
7	Jaw Inserts, regular (set of 2)	319	5.54	619	11.09	819	14.017
7	Jaw Inserts, hardened (set of 2)	319H	8.62	619H	14.17	819H	17.25
8	1/4-20 x 3/4 Screw (6 required)	--	--	30-3/4	0.54	30-3/4	0.54
8	1/4-20 x 1/2 Screw (4 required)	30-1/2	0.54	--	--	--	--

Note 1. Prices not shown, as replacement jaw castings are not available. Jaws must be machined in pairs.

WHEN ORDERING PARTS, INDICATE PART NUMBER, MODEL NUMBER AND PRICE.

BAND SAW VISE

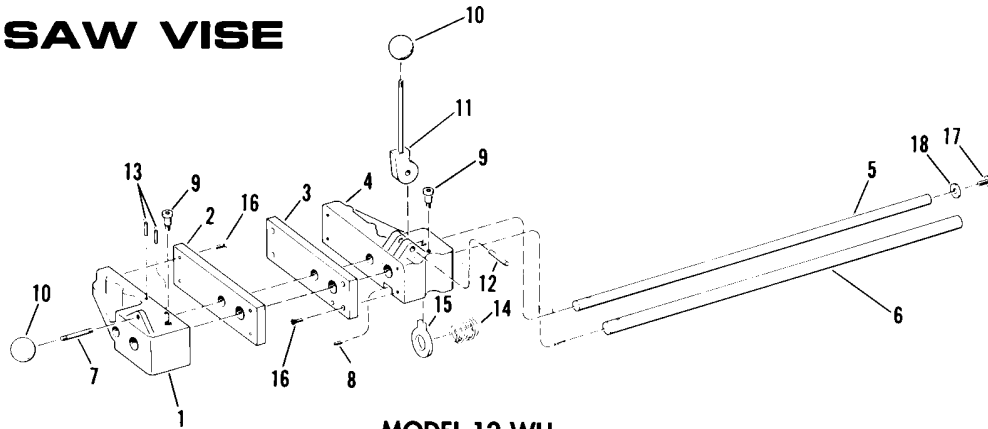

MODEL 12-WH

Index No.	Part Name	Part No.	Price
1	Stationary Jaw Casting (Note 1)	12WH-1	--
2 & 3	False Jaws (Set of 2)	12WH-2 & 3	\$23.54/pair
4	Movable Jaw Casting (Note 1)	12WH-4	--
5	Guide Bar	12WH-5	4.56
6	Locking Bar	12WH-6	18.48
7	Handle Stud	12WH-7	1.88
8	1/4-20 x 3/4 Screw	12WH-8	0.54
8A	1/4-20 x 1/2 Screw	12wh-8A	0.54
9	Chain Stud	12WH-9	2.94
10	Knob -- 3/8-24 thread (2 required)	SV-6821	2.03
11	Handle Lever Assembly	12WH-11	11.77
12	5/16 x 1 1/8 Rollpin	12WH-12	0.68
13	3/16 x 1 1/8 Rollpin (2 required)	2316-A	0.35
14	Spring	PA-6817	1.77
15	Locking Ring	SV-6816	13.55
16	1/4-20 x 1/2 Screw (8 required)	30-1/2	0.54
17	5/16-24 x 1/2 Screw	H-14	0.59
18	1/4" USS Washer	305-26	0.24

Note 1. Prices not shown, as replacement jaw castings are not available. Jaws must be machined in pairs.

SEE OPERATION AND MAINTENANCE INSTRUCTIONS FOR GRIP-MASTER VISES ON THE GRIP-MASTER VISES PAGE.

WHEN ORDERING PARTS, INDICATE PART NUMBER, MODEL NUMBER AND PRICE.