



Grip-Master FIXTURE LOCKS

PRICES OF FIXTURE LOCKS WITH SPECIAL BAR LENGTHS

	2-FL	2-PA
10"	\$63.00	\$77.00
12"	64.70	79.90
14"	65.30	80.50
16"	67.60	82.80
18"	70.00	85.10
20"	72.30	87.50
24"	74.60	89.80

	9-FL	9-PA
12"	78.10	96.80
14"	80.50	99.10
16"	82.80	101.40
18"	85.10	103.80
20"	87.50	106.10
24"	89.80	108.40

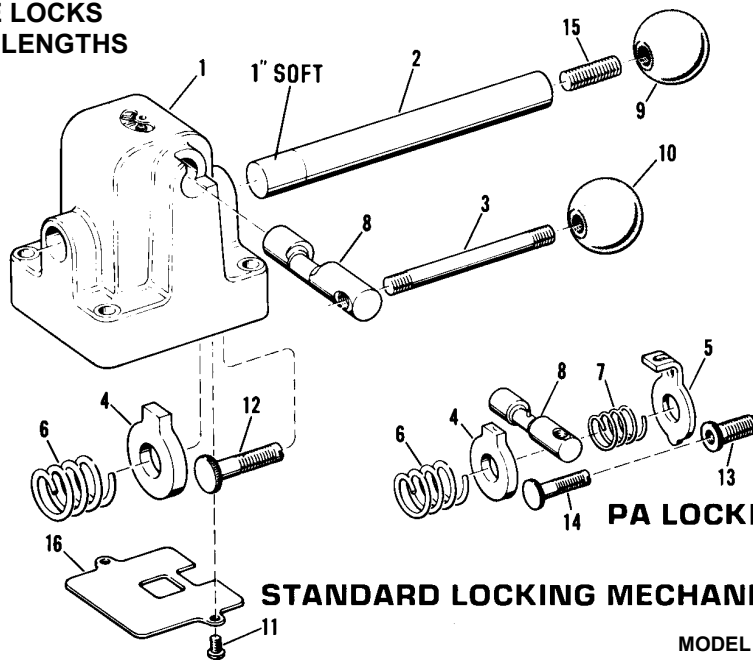

Index No.	Part Name	MODEL NUMBER			
		2-FL 2-PA**		9-FL 9-PA**	
		Part No.	Price	Part No.	Price
1	Body Casting (Note 1)	2-FL	--	9-FL	--
2	Bar, Locking, Standard	213-9"	\$8.62	913-20"	\$12.32
2	Bar, Special	213-10"	9.86	--	--
2	Bar, Special	213-12"	11.70	913-12"	17.25
2	Bar, Special	213-14"	12.32	913-14"	19.71
2	Bar, Special	213-16"	14.78	913-16"	22.18
2	Bar, Special	213-18"	17.25	913-18"	24.64
2	Bar, Special	213-20"	19.71	913-20"	27.10
2	Bar, Special	213-24"	22.18	913-24"	29.57
3	Handle	GM-3415	1.23	6815	1.85
4	Locking Ring	SV-3416	9.24	SV-6816	13.55
5	Holding Ring	PA-3416**	7.39	PA-6816**	11.70
6	Spring, Locking	GM-417	2.03	6817	1.65
7	Spring, Holding	PA-3417**	5.40	PA-6817**	1.77
8	Crank	GM-3418	5.54	GM-6818	8.62
8	Crank, with 1/8" Pin	GMPA-3418**	7.39	GMPA-6818**	11.09
9	Knob, Black -- 1" Dia., 1/4-20 thread	SV-3421	1.80	--	--
9	Knob, Red -- 1" Dia., 1/4-20 thread	RSV-3421**	1.77	--	--
9	Knob, Black -- 1 1/2" Dia., 3/8-24 thread	--	--	SV-6821	2.03
9	Knob, Red -- 1 1/2" Dia., 3/8-24 thread	--	--	RSV-6821**	3.20
10	Knob, Black -- 1 1/8" x 1 7/16" oval, 3/8-16 thread	OA-3421	1.94	--	--
10	Knob, Red -- 1 1/8" x 1 7/16" oval, 3/8-16 thread	ROA-3421**	3.33	--	--
10	Knob, Black -- 1 1/2" Dia., 3/8-24 thread	--	--	SV-6821	2.03
10	Knob, Red -- 1 1/2" Dia., 3/8-24 thread	--	--	RSV-6821**	3.20
12	Screw	SV-31	0.82	SV-31	0.82
13	Adjusting Screw -- Female	PA-32**	3.56	PA-32**	3.56
14	Adjusting Screw -- Male	PA-33**	3.56	PA-33**	3.56
15	Stud	3423	0.50	6823	0.59
16	Cover Plate	3437	0.89	6837	1.18

Recommended spare part to be retained in stock at all times to support each unit: Index (4) locking ring, Index (2) bar.
SEE OPERATION AND MAINTENANCE INSTRUCTIONS FOR GRIP-MASTER VISES ON THE GRIP-MASTER VISES PAGE

WHEN ORDERING PARTS, INDICATE PART NUMBER, MODEL NUMBER AND PRICE.