

heinrich

AIR VISES ... double acting air cylinders

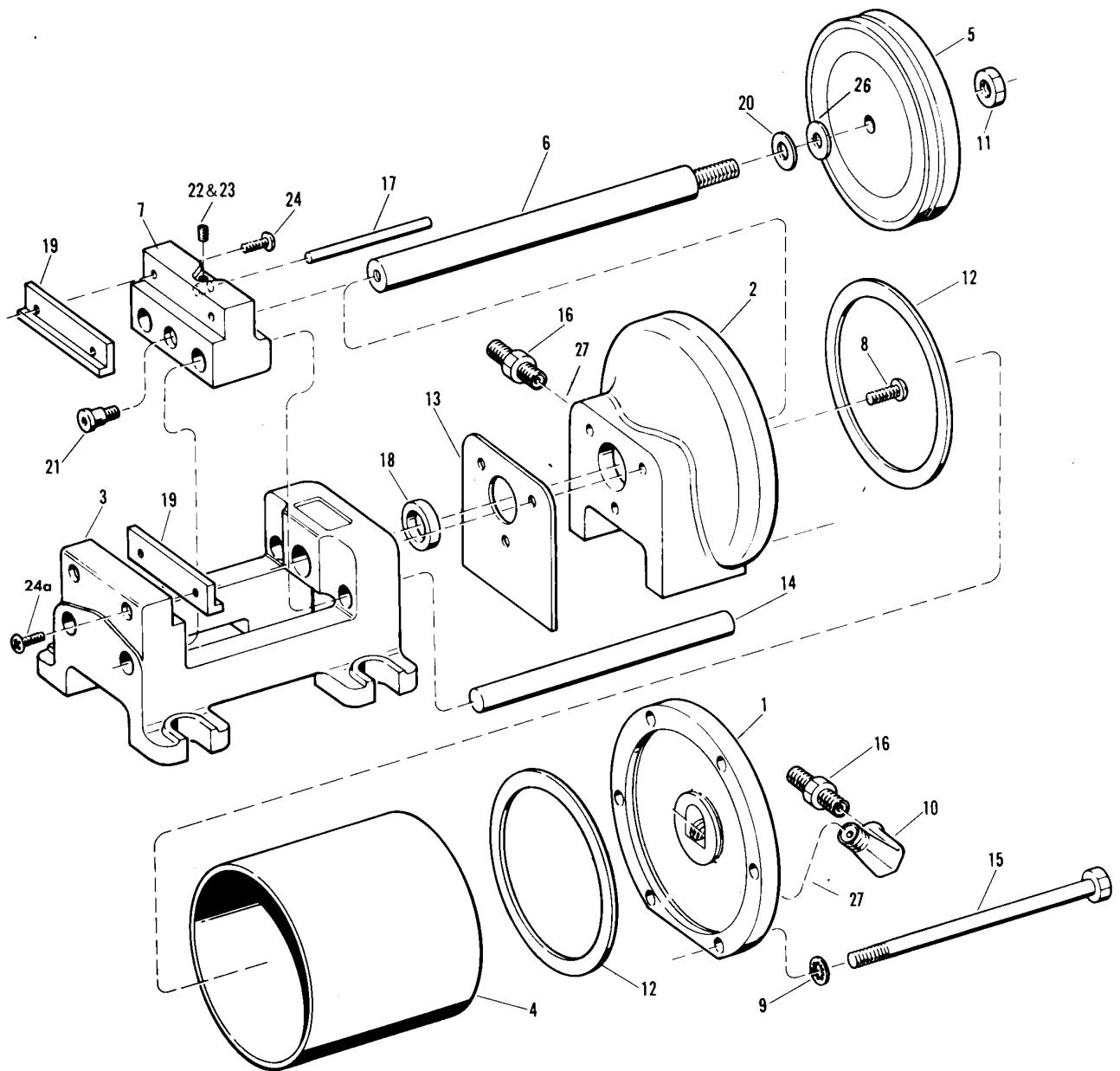

CAUTION: For maximum operator protection when the setup might cause the employee to place his hands or fingers within the point of operation, we suggest a two-hand control device, available through your air accessories distributor.

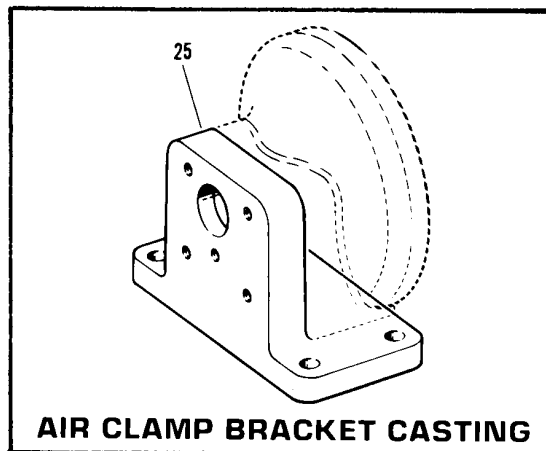

AIR CLAMP BRACKET CASTING

Index No.	Part Name	MODEL NUMBER					
		DA-3301 VISE DA-5503 CLAMP		DA-4401 VISE OA-5504 CLAMP		DA-6601 VISE	
		Part No.	Price	Part No.	Price	Part No.	Price
1	Cylinder Head	3301-1	\$15.81	3301-1	\$15.81	6601-1	\$31.63
2	Cylinder Body	3301-2	27.83	3301-2	27.83	--	--
3	Body Casting (Note 1)	33-3	--	44-3	--	6601-3	--
4	Cylinder Tube	3301-4	51.93	4401-1	61.79	6601-4	110.97
5	Piston Cup	3301-5	33.35	3301-5	33.35	6601-5	39.47
6	Piston Rod for Vise	3301-6	9.24	4401-6	10.47	6601-6	19.71
6	Piston Rod for Clamp	5503-6	13.55	5504-6	14.17	--	--
7	Jaw Casting	3301-7	21.51	4401-7	25.30	6601-7	78.43
8	5/16-18 x 3/4 Screw (3 required)	33-8	0.47	33-8	0.47		
9	5/16" I.D. Star Washer (6 required)	3301-9	0.24	3301-9	0.24	3301-9 (5x)	0.24
10	Elbow	2200-33	2.94	2200-33	2.94	--	--
11	1/2-20 x Jam Nut	3301-11	0.54	3301-11	0.54	--	--
11	3/4-16 Jam Nut	--	--	--	--	6601-11	1.77
12	Cylinder Gasket (2 required)	3301-12	2.39	3301-12	2.39	6601-12	3.06
13	Body Gasket	3301-13	1.61	3301-13	1.61	3301-13	1.61
14	Guide Bar (2 required)	314	3.70	44-14	4.31	814	12.32
15	Cylinder Tie Rod (6 required)	3301-15	1.41	4401-15	1.65	6601-15 (5x)	2.59
16	Adapter (2 required)	33-16	1.77	33-16	1.77	33-16	1.77
17	Stop Bar	3301-17 3/8" Dia. x 3 1/4"	1.53	4401-17 3/8" Dia. x 4 3/4"	2.35	6601-17 1/2 Dia. x 8 1/4"	2.71
18	U-Packing	3301-18	4.12	3301-18	4.12	6601-18	4.95
19	Jaw Inserts, regular (set of 2)	319	5.54	44-19	7.39	619	11.09
19	Jaw Inserts, hardened (set of 2)	319H	8.62	44-19H	10.47	619H	14.17
20	Stat-O-Seal	600-1/2	1.65	600-1/2	1.65	600-3/4	2.61
21	Shoulder Screw	3301-39	3.41	3301-39	3.41	6601-39	8.48
22	1/4-28 x 3/8" Screw	305-20	0.47	305-20	0.47	--	--
23	1/4-20 x 3/8 Screw	--	--	--	--	6601-23	0.47
24	1/4-20 x 5/8 Screw	30 5/8	0.54	30 5/8	0.54	--	--
24	1/4-20 x 3/4 Screw	30 3/4	0.54	30 3/4	0.54	30 3/4	0.54
25	Bracket Casting	55-1	65.78	55-1	65.78	--	--
26	Back-up Washer	3301-5A	4.71	3301-5A	4.71	--	--
27	Bushing, reducer	--	--	--	--	6601 (2X)	2.75

Note 1. Price not shown, as replacement body castings are not available.

WHEN ORDERING PARTS, INDICATE PART NUMBER, MODEL NUMBER AND PRICE.

OPERATION:

Connect one of the three identical hoses to the air supply line and to the adapter on the four-way valve marked "IN." Connect the other two hoses to the two adapters on the four-way valve marked "CYL" (cylinder) and to the two adapters on the cylinder.

Heinrich air units can be used safely on air supply lines with pressures up to 120 psi.

The amount of jaw return may be regulated by cutting off the stop bar (17) for size opening required.

The range of holding power can be controlled by installing an Air Regulator between the air supply line and the three-way valve.

While all operating parts are protected from oils, coolants,

chips, etc., the air cylinder and controls could be damaged by foreign matter in the air supply line. This can be prevented by using an Air Filter between the air supply and the air regulator and/or control valve. A Combination Filter-Regulator may be used in place of the individual filter and regulator.

MAINTENANCE:

An occasional oiling of the guide bars and piston is recommended. If the vise becomes inoperable, disassemble as shown in exploded view. Clean and check each part for wear or damage. Replacement parts are available for immediate shipment from factory stock, or you may order through your local Heinrich distributor. When reassembling, all screws and nuts should be evenly and securely tightened.