

DMTRT SERIES 2-SPINDLE TILTING ROTARY TABLE

FEATURES:

- ▶ Two spindle models available in 140mm and 170mm table diameter sizes
- ▶ Very compact design
- ▶ Can be supplied as programmable style (using UDNC-M2) or as full fourth or fifth axis, using FanucMitsubishi, Yaskawa, or other motors
- ▶ High torque dual disc brake design with loading ring for maximum rigidity, permitting heavy cutting
- ▶ Class "A" dual tapered roller spindle bearings providing for smooth rotation even under the heaviest thrust loads



DMTRT-140-2



UDMC-M2

MODEL		DMTRT 140-2	DMTRT 170-2
SUB TABLE D.		5.51 (140)	6.69 (170)
CENTER HEIGHT @90°		8.27 (210)	8.27 (210)
MAX RPM	ROTARY	55.5	55.5
	TILTING	11.1	11.1
SPINDLE TORQUE ft-lbs (kg-m)	ROTARY	30 (41)	37 (51)
	TILTING	188 (26)	188 (26)
GEAR RATIO	ROTARY	72 : 1	72 : 1
	TILTING	360 : 1	360 : 1
MAX WORK LOAD CAPACITY lbs (kg)	0° (horizontal)	110 (50)	132 (60)
	@ 90°	55 (25)	66 (30)
RESOLUTION DEGREE		0.000625	0.000625
SPINDLE BRAKE TORQUE lbs (kg-m)	ROTARY	65 (9)	108 (15)
	TILTING	615 (85)	868 (120)
MAX WORK INERTIA lbs/inch/sec ² (kg/cm/sec ²)		1.24 (1.43)	1.86 (2.14)
MAX TRUST LOAD lbs (kg) (horizontal)		1100 (500)	1320 (600)
MAX CUTTING TORQUE lbs.(kg)	TILTING	80 (11)	108 (15)
	BRAKE ON	217 (30)	289 (40)
INDEXING ACCURACY	ROTARY	+/- 22.5 seconds	
	TILTING	+/- 30 seconds	
REPEATABILITY		6 seconds	
SPINDLE THRU HOLE DIA.		1.26 (32)	1.77 (45)
NET WEIGHT lbs (kg)		441 (200)	529 (240)

DIMENSIONAL SPECIFICATIONS

EACH UNIT SUPPLIED WITH:

- ▶ UDNC-M2 controller for DMTRT
- ▶ DMTRT unit complete with rotary drive unit, end support and mounting plate
- ▶ Power cable (105~240 single phase VAC, 20 Amp)
- ▶ Remote cable for M-code interface to CNC
- ▶ Operator's manual, test report, warranty card and locating keys

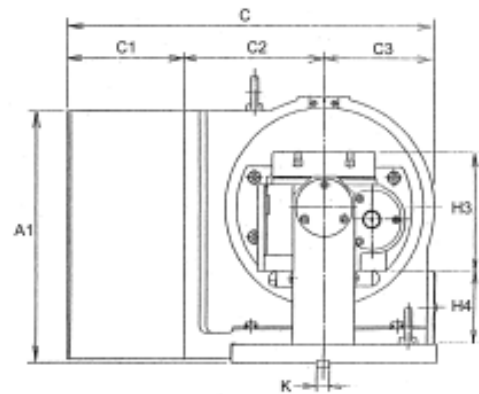
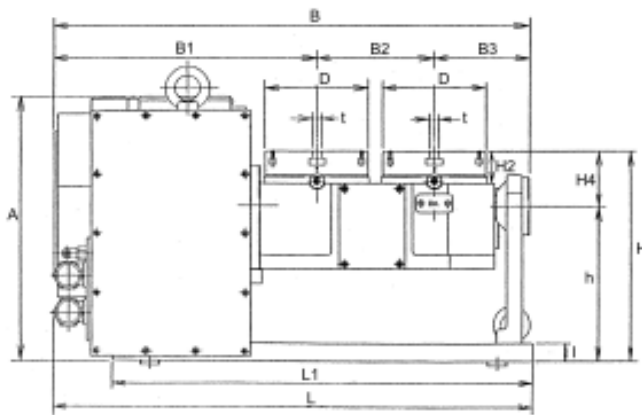
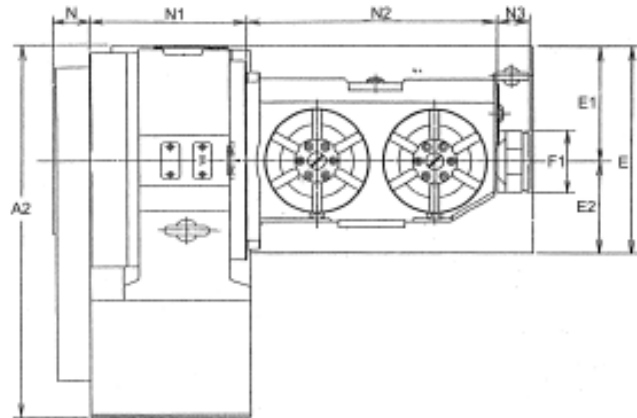

Inch (mm)

MODEL	A	A1	A2	B	B1	B2	B3	C	C1	C2	C3
DMTRT140-2	14.17 (360)	13.39 (340)	19.88 (505)	25.39 (645)	13.98 (355)	6.3 (160)	5.12 (130)	19.69 (500)	6.3 (160)	7.48 (190)	5.91 (150)
DMTRT170-2	14.37 (365)	13.39 (340)	19.88 (505)	28.54 (725)	14.57 (370)	7.87 (200)	6.10 (155)	19.88 (505)	6.3 (160)	7.48 (190)	6.10 (155)

MODEL	D	E	E1	E2	F	h	H	H2	H3	H4
DMTRT140-2	5.51 (140)	11.02 (280)	6.10 (155)	4.92 (125)	3.31 (84)	8.27 (210)	11.22 (285)	1.34 (34)	6.30 (160)	3.94 (100)
DMTRT170-2	6.69 (170)	11.02 (280)	6.10 (155)	4.92 (125)	5.12 (130)	8.27 (210)	11.4 (290)	1.38 (35)	6.69 (170)	3.74 (95)

MODEL	I	K	t	L	L1	N	N1	N2	N3
DMTRT140-2	0.98 (25)	0.708 (18)	0.47 (12)	25.59 (650)	22.44 (570)	1.97 (50)	8.27 (210)	13.39 (340)	1.77 (45)
DMTRT170-2	0.98 (25)	0.708 (18)	0.47 (12)	28.74 (730)	25.59 (650)	1.97 (50)	8.27 (210)	16.54 (420)	1.77 (45)