



# DMNC SERIES



## ROTARY TABLE BODY FEATURES INCLUDE:

**Split Worm Gear Set:** This precision worm boasts of multi-tooth (8 or 9 teeth) worm gear engagement providing maximum torque to the rotary table spindle (a typical single lead worm has only 2 or 3 tooth engagement to the worm wheel gear). Also, our split worm design means that only minimum backlash (0.0002") is needed to allow rotary table movement. This small backlash value ensures a much higher positioning accuracy and more rigidity.

**Heavy Duty Dual Disc Brake System:** Our patented brake design (dual disc) can be used as pneumatic (standard) or hydraulic (optional). When you order your DMNC rotary table, you can specify either pneumatic spindle brake, or for a small additional cost we can prepare your rotary table to include hydraulic spindle brake for very heavy off-center cutting.

**Main Spindle Bearing Set:** Main spindle features a large diameter, heavy, duty class "A", high accuracy, long contact ball bearing combined with heavy dual thrust bearings. This massive bearing set is designed for heavy workpiece loads under maximum cutting conditions.

**Main Spindle Seal:** Double-lip, spring-loaded oil seal located directly around the spindle protects the worm gear and bearing from outside contamination.

**Meehanite Main Body:** The main rotary table body has machined dual "O" ring grooves for a "perfect seal" between the die cast aluminum motor cover to the rotary table body.

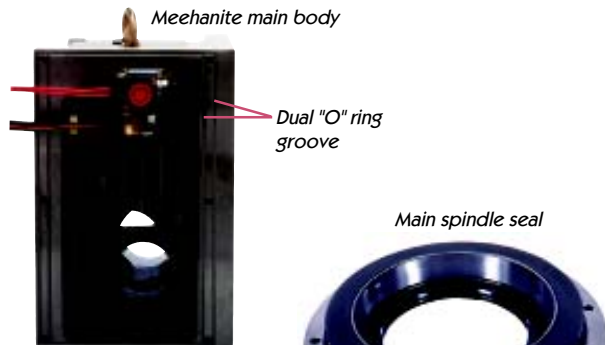

# UDNC M1/M2 PROGRAMMABLE CONTROLLER

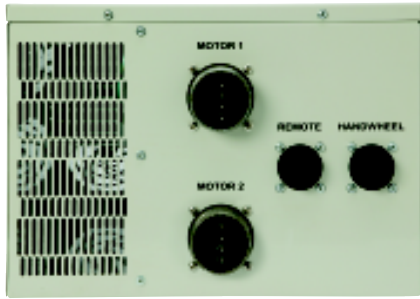

Side View



UDNC-M2 CONTROLLER



Communication Ports



Digital Servo Amplifier

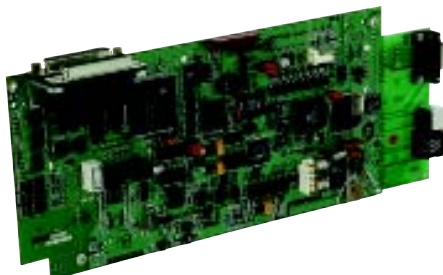

Motion Controller

We are excited to introduce our new UDNC-M1 (single axis) and UDNC-M2 (dual axis) programmable controllers. These new controllers feature the latest in digital servo technology with enhanced motion control capabilities.

Nine (9) pin serial port (RS232C) along with a USB port is provided along with Windows<sup>®</sup> based programming software allowing for off-line programming and program storage.

The unit features direct rotary table operation using a macro "DPRNT" command from the CNC control.

An optional Ethernet port is also offered for diagnostic access from our service department directly to your UDNC controller in your plant.

Our UDNC-M1 and M2 controllers include our new digital servo amplifier providing more than 30 amp output to the digital AC servo motor ensuring maximum power for turning heavy loads. This revolutionary integrated power block technology provides more power as required while maintaining smooth servo operation for helical type cutting.

This fully digital motion control features the latest Motorola<sup>®</sup> DSP digital processor. This highly integrated motion controller has minimal closed servo loop delays, resulting in the opportunity for higher gains (servo stiffness) for better servo tracking.

## OTHER FEATURES INCLUDE:

- Standard M & G code functions
- 100-program storage memory
- Auto backlash compensation
- Pitch error compensation
- Manual pulse generator
- Remote program step from PC
- Dual cooling fans
- Fully protected (from outside contamination)
- Helical cutting capability
- Incremental jog (to 0.0001" sec.)
- 64-bit microprocessor
- 100 RPM indexing speed

# DMNC CONNECTION DIAGRAM

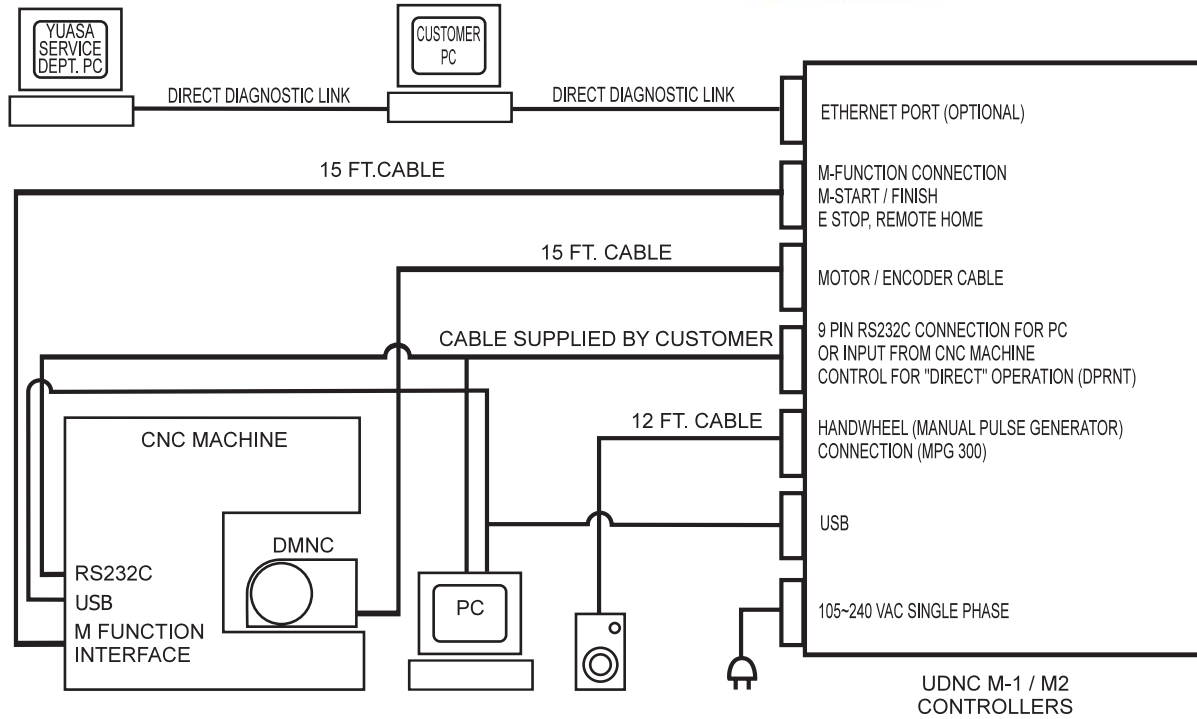

## INTERFACE OPTIONS TO CNC MACHINES

There are two primary methods of operation of the DMNC units with controllers. The first is by connecting the remote cable (supplied with each DMNC unit), to a spare M Code (Start and Finish). With this method, a program is written and stored into the UDNC controller, then each step is executed (sequentially) by the M Code output from the CNC machine control. The second method is described on page #11.

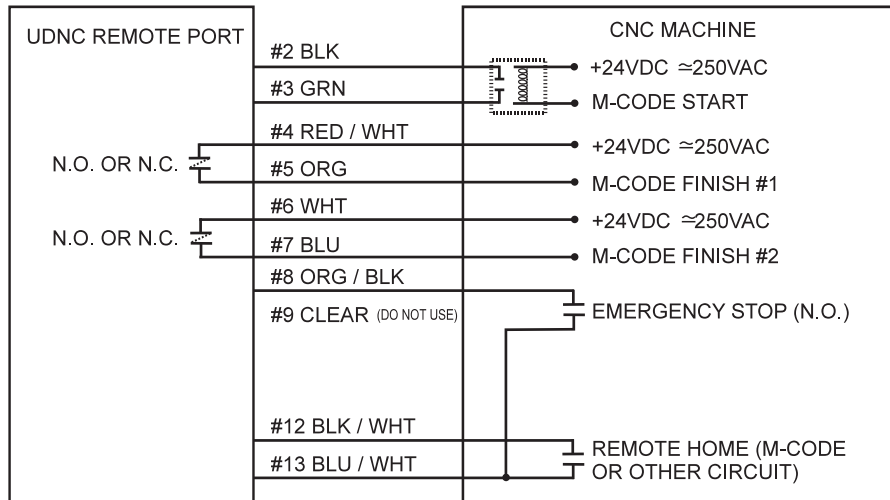

# INTERFACE TO CNC MACHINE VIA RS232C OR USB PORT



## MACRO METHOD BENEFITS

This method clearly has a number of advantages over a typical M Code installation.

- ▶ No need to write a separate program for the indexer controller. Only the CNC machine program is required, which includes the rotary movements. This also means that all index movements are stored in the same machine program, so re-running the same job is as easy as loading the CNC machine program.
- ▶ Provides the ability re-start/re-run the CNC machine program at any block and the rotary indexer will move to the command position, regardless of the previous rotary position.
- ▶ At any time you can view the machine CRT and see the rotary table position, relative to the rest of the machine program.
- ▶ Macro programming allows for math variables such as partial indexes, etc.

## CNC Machine Requirements

- ▶ Macro "B" or equivalent
- ▶ Spare M Code
- ▶ RS232 serial cable or USB cable

## Set Machine Protocol

Most CNC machine controls communicate using the 7 or 8 data bit format. This, along with baud rate can be set into the UDNC controller, using parameter settings. Proper communication settings between the machine control and the UDNC controller are essential for operation. (Please note that some CNC controls may not allow this function to work due to software compatibility issues.)

UDNC - M1 / M2



## Example of a Macro Program for the CNC Control (EXAMPLES ONLY)

### DPRNT line for UDNC-M1

```
%  
9010  
POPEN;  
DPRNT[G90F100A#1];  
PCLOS;  
M21; - (example of machine M-code)  
M99;  
%
```

### DPRNT line for UDNC-M2

```
%  
9011  
POPEN;  
DPRNT[G90F100A#1B#2];  
PCLOS;  
M21; - (example of machine M-code)  
M99;  
%
```

Once this is done all that is required in the machine program, is to first insert the macro program call "G15", for example, then the variable #1="A" <move>. The CNC program line would be **G15A60**. This would provide an absolute rotary move to 60 degrees position. As you can see, this is the simplest programming method available today.

NOTE: Ethernet port (opt.) is available for diagnostic access from our service department directly to your UDNC controller.



# DMNC SERIES ROTARY TABLE MODELS (Single Spindle)



MODELS 400~130



Ultra-precision Split Worm Gear



UDNC-M1



DHB 130~320

Inch/(mm)

MODEL / DMNC	130	170	220	280	320	400	500	630	800	
SUB TABLE	O.D.	5.12 (130)	6.69 (170)	8.66 (220)	11.02 (280)	12.60 (320)	15.75 (400)	19.68 (500)	24.80 (630)	31.50 (800)
	BORE I.D.	1.18 (30)	1.65 (42)	1.65 (42)	1.65 (42)	1.65 (42)	1.65 (42)	N/A	N/A	N/A
THREADED I.D.	N/A	M36 P3.0	M36 P3.0	M36 P3.0	M36 P3.0	M36 P3.0	N/A	N/A	N/A	N/A
CENTER HEIGHT inch.(mm)	4.13 (105)	5.12 (130)	6.30 (160)	7.48 (190)	8.66 (220)	11.10 (280)	12.20 (310)	16.54 (420)	18.90 (480)	
MAX PRM	100	75	50	36		25		11.1		
SPINDLE TORQUE ft.lbs.(Kg.m)	90 (12)	165 (23)	195 (27)	780 (108)	810 (112)	789 (109)	1,450 (200)	1,965 (272)	2,640 (365)	
SPINDLE BRAKE TORQUE lbs.ft (kg.m)										
PNEUMATIC BRAKE	50 (6.9)	110 (15)	180 (25)	325 (45)	480 (66)	N/A		N / A		
HYDRAULIC BRAKE	108 (15)	217 (30)	352 (49)	515 (71)	623 (86)	789 (109)	855 (118)	941 (130)	1,231 (170)	
RESOLUTION (degree)	0.001"	0.00075"	0.0005"	0.000375"		0.00025"				
MAX LOAD HORIZONTAL (TABLE POSITION) lbs. (Kg)	66 (30)	180 (80)	260 (120)	400 (180)	550 (250)	1,100 (500)	2,156 (980)	3,300 (1,500)	4,400 (2,000)	
MAX LOAD VERTICAL (TABLE POSITION) lbs. (Kg)	33 (15)	90 (40)	130 (60)	200 (90)	275 (125)	770 (350)	1,045 (475)	1,430 (650)	1,650 (750)	
POSITIONING ACCURACY	+/- 10 seconds					+/- 7.5 seconds				
REPEATABILITY	+/- 2 seconds									
MOTOR TYPE	Digital AC Servo									
SETTING POSITION	HORIZONTAL OR VERTICAL									
THRU HOLE DIAMETER Inch (mm)	1.44 (36.5)	1.77 (45)	2.50 (63.5)	3.54 (90)	4.33 (110)	6.69 (170)	10.0 (254)	10 (254)		
POWER SUPPLY	105 ~ 240 VAC Single Phase 20 Amp									
GEAR RATIO	45 : 1	60 : 1	90 : 1	120 : 1		180 : 1				
SPINDLE RUNOUT Inch (mm)	0.006 (0.02)									
T-SLOTTED FACE PLATE	4-SLOT		6-SLOT			8-SLOT				
NET WEIGHT lbs. (kg)	70 (32)	108 (49)	180 (82)	282 (128)	418 (190)	682 (310)	1,131 (513)	1,815 (824)	2,750 (1,248)	

CNC ROTARY PRODUCTS

MODEL	SPINDLE SPECIFICATIONS							CHUCK DIMENSIONS				
	D1	d	d1	PCD-M	H1	H3	H4	H5	H7	Inner Jaw	Outer Jaw	I.D.
DMNC 130	4.01 (102)	2.76 (70)	1.44 (36.5)	2.36-M5 (60)-M5	0.18 (4.5)	0.65 (16.5)	1.81 (46)	0.63 (16)	7.87 (200)	0.12~1.18 (3~30)	0.12~3.39 (3~86)	1.26 (32)
DMNC 170	6.57 (167)	3.35 (85)	1.77 (45)	2.44-M8 (62)-M8	0.28 (7)	0.71 (18)	2.68 (68)	1.79 (45.4)	10.49 (266.4)	0.16~1.65 (4~4.2)	0.39~6.14 (10~156)	1.73 (44)
DMNC 220	8.27 (210)	4.33 (110)	2.50 (63.5)	3.54-M8 (90)-M8	0.31 (8)	0.79 (20)	2.95 (75)	1.84 (46.8)	11.76 (298.8)	0.16~2.44 (4~62)	0.39~7.09 (10~180)	2.48 (63)
DMNC 280	10.79 (274)	5.51 (140)	3.54 (90)	4.57-M10 (116)-M10	0.35 (9)	0.87 (22)	3.58 (91)	2.13 (54.2)	13.55 (344.2)	0.16~3.46 (4~88)	0.47~9.06 (12~230)	3.54 (90)
DMNC 320	12.2 (310)	6.3 (160)	4.33 (110)	5.35-M10 (136)-M10	0.35 (9)	0.98 (25)	3.78 (96)	2.28 (58)	14.8 (376)	0.20~4.25 (15~188)	0.59~10.43 (15~265)	4.33 (110)

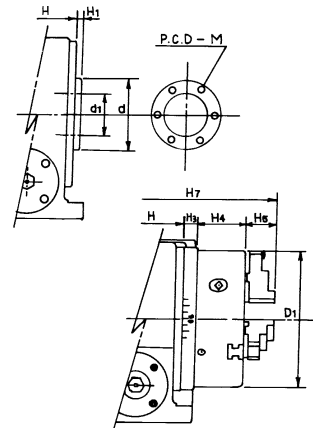

NOTE: For controller features see page #9. For rotary table (body) features see page #8. Left hand motor mounted models are available, by request. Rear mounted motor models are available on request.

# OVERALL DIMENSIONAL SPECIFICATIONS

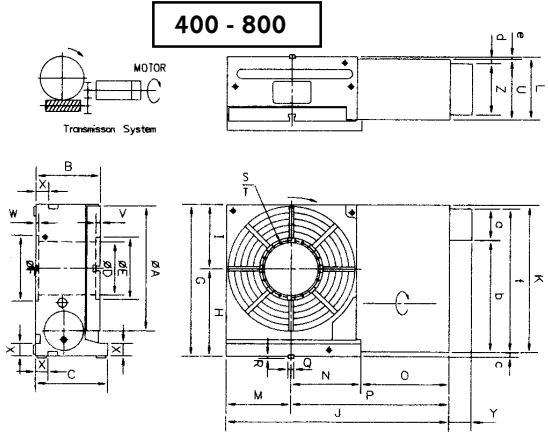
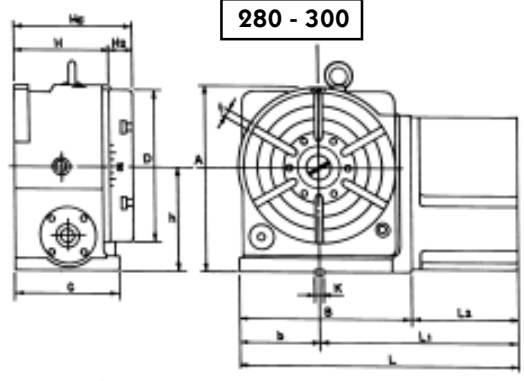
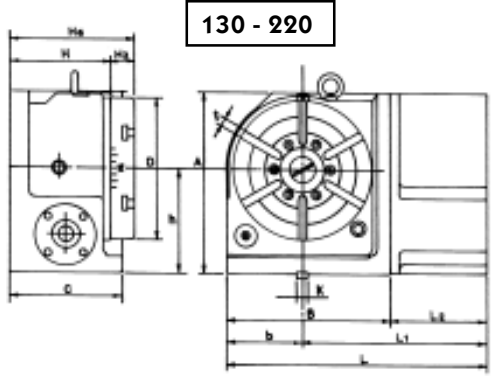

## STANDARD ACCESSORIES

- ▶ UDNC-M1 Controller
- ▶ Remote Cable (for M-code Interface, 15 ft.)
- ▶ Power cord (105~240 VAC, single phase)
- ▶ Operators Manual, Warranty Card, Locating Keys
- ▶ T-slotted Face Plate (130 -320 removable)

## OPTIONAL ACCESSORIES

- ▶ Handwheels (MPG-300)
- ▶ Remote quill switch (RQS-100) for manual mills
- ▶ Collet Chucks, Lathe Chucks, etc.
- ▶ Tailstocks (manual & air operated)
- ▶ Vise and collet block trunion fixtures
- ▶ PC Programming software
- ▶ RS232 cable for DPRNT

Unit: inch (mm)

MODEL	A	B	b	C	D	L	L1	L2	H	H2	H6	t	h	k
DMNC 130	7.87 (200)	6.57 (167)	3.03 (77)	5.31 (135)	5.12 (130)	12.28 (312)	9.25 (235)	5.71 (145)	4.78 (121.5)	1.12 (33.5)	5.91 (155)	0.39 (10)	4.13 (105)	0.55 (14)
DMNC 170	9.25 (235)	8.46 (215)	3.94 (100)	5.91 (150)	6.69 (170)	15.55 (395)	11.61 (295)	7.09 (180)	5.31 (135)	1.38 (35)	6.69 (170)	0.47 (12)	5.12 (130)	0.71 (18)
DMNC 220	11.02 (280)	10.24 (260)	4.72 (120)	6.89 (175)	8.66 (220)	18.11 (460)	13.38 (340)	7.87 (200)	6.18 (157)	1.50 (38)	7.68 (195)	0.47 (12)	6.3 (160)	0.71 (18)
DMNC 280	13.39 (340)	12.60 (320)	5.91 (150)	7.68 (195)	11.02 (280)	20.47 (520)	14.57 (370)	7.87 (200)	6.97 (177)	1.69 (43)	8.66 (220)	0.47 (12)	7.48 (190)	0.71 (18)
DMNC 320	15.35 (390)	14.17 (360)	6.69 (170)	8.66 (220)	12.60 (320)	22.05 (560)	15.35 (390)	7.87 (200)	7.76 (197)	1.89 (48)	9.65 (245)	0.55 (14)	8.66 (220)	0.71 (18)
DMNC 400	19.09 (485)	8.07 (205)	14.09 (358)	9.06 (230)	6.69 (170)	7.99 (203)	20.28 (515)	11.61 (295)	N/A	N/A	8.07 (205)	0.71 (18)	11.02 (280)	0.71 (18)

MODEL	A	B	C	D	E	F	G	H	I	J	K	L	M	N
DMNC 500	19.68 (500)	9.84 (250)	9.25 (235)	10.0 (254)	9.65 (245)	9.65 (245)	22.05 (560)	12.2 (310)	9.84 (250)	31.81 (818)	14.6 (371)	9.25 (235)	9.84 (250)	10.04 (255)
DMNC 630	24.08 (630)	11.81 (300)	11.61 (295)	10.00 (254)	11.61 (295)	11.61 (295)	28.35 (720)	15.75 (400)	12.60 (320)	40.94 (1,040)	15.75 (400)	9.76 (248)	12.60 (320)	13.19 (335)
DMNC 800	31.50 (800)	13.58 (345)	13.19 (335)	10.00 (254)	11.61 (295)	11.61 (295)	34.65 (880)	18.90 (480)	15.75 (400)	44.17 (1,122)	19.84 (504)	10.91 (277)	15.75 (400)	16.34 (415)

MODEL	O	P	Q	R	S	T	U	V	W	X	Y	Z
DMNC 500	11.93 (303)	21.97 (558)	.7h (17.7h)	0.276 (7)	P10.83 (P275)	.31-M.39 (8-M10)	9.25 (235)	0.59 (15)	0.79 (20)	3.14 (80)	2.76 (70)	6.77 (172)
DMNC 630	15.16 (385)	28.35 (720)	0.87h.28 (22h7)	0.28 (7)	P10.83 (P275)	.31-M.39 (8-M10)	9.57 (243)	0.79 (20)	0.79 (20)	1.97 (50)	2.76 (70)	7.87 (200)
DMNC 800	12.09 (307)	28.43 (722)	0.87h.28 (22h7)	0.28 (7)	P10.83 (P275)	.31-M.39 (8-M10)	10.63 (270)	0.79 (20)	0.79 (20)	1.97 (50)	2.76 (70)	7.87 (200)

MODEL	a	b	c	d	e	f	g	h	i	j
DMNC 500	4.06 (103)	10 (254)	1.14 (29)	0.55 (14)	0.2 (5.08)	12.09 (307)	.71h.28 (17.7h7)	1.18 (30)	0.71 (18)	0.47 (12)
DMNC 630	3.94 (100)	11.81 (300)	3.54 (90)	0.59 (15)	0.28 (7.1)	15.75 (400)	.71h.28 (17.7h7)	1.18 (30)	0.71 (18)	0.47 (12)
DMNC 800	3.94 (100)	17.2 (437)	2.09 (53)	0.59 (15)	0.28 (7.1)	19.06 (484)	.87h.28 (22h7)	1.5 (38)	0.87 (22)	0.63 (16)

NOTE: See pages 32-37 for detailed information on DMNC accessories.

CNC ROTARY PRODUCTS