

MAINTANCE MANUAL

CNC ROTARY TABLE

MODEL: DMNC-5C

YUASA INTERNATIONAL.

INDEX

DESCRIPTION

PAGE

(1)SPECIFICATION

2

(2)OUTSIDE DIMENSION LAYOUT

3

(3)INSPECTION REPORT

4

(4)PREPARATION FOR OPERATION

5

4-1.LUBRICATING OIL

5

(5)TRIAL RUNNING

6

5-1.PREPARATION FOR MOTOR DRIVING

6

5-2.TRIAL RUNNING

6

5-3.DISTANCE SETTING OF SPINDLE

6

(6)WORK-PIECE MOUNTING

7

(7)BACKLASH ADJUSTMET FOR
WORM SHAFT & WHEEL

9

7-1.MEASUREMENT OF BACKLASH

9

7-2.VALVE OF BACKLASH ADJUSTING

11

(8)STRUCTION OF ZERO-RETURN

12

8-1.ZERO-RETURN

12

8-2.ADJUSTMENT OF DOG

12

(9)MAINTAINANCE AND SERVICE

12

(10)EXPLODED VIEW & PART LIST

13

(1) SPECIFICATION

	ITEM	UNIT	DMNC-5C	REMARK
1.	CENTER HIGH IN VERTICAL	mm	110	
2.	OVERALL HIGH IN VERTICAL	mm	223	
3.	OVERALL LENGTH	mm	333	P5
4.	OVERALL WIDTH	mm	201	
5.	WIDTH FOR T-SLOT	mm	18h7	
6.	SERVO MOTOR	SANYO	P50B07030	
		FANUC	α 2i	
7.	GEAR RATIO		1:45	
8.	MAX. INDEXING	DEGREE	0.001	
	MAX. SPEED FOR ROTATING	r.p.m.	44.4	2000r.p.m
9.	MAX. MACHINE FORCE	kg-m	10	
10.	POSITIONING ACCURACY	sec	60	
11.	REPEATABILITY	sec	\pm 2	
12.	NET WEIGHT	kg	30	

(2) OUTSIDE DIMENSION LAYOUT

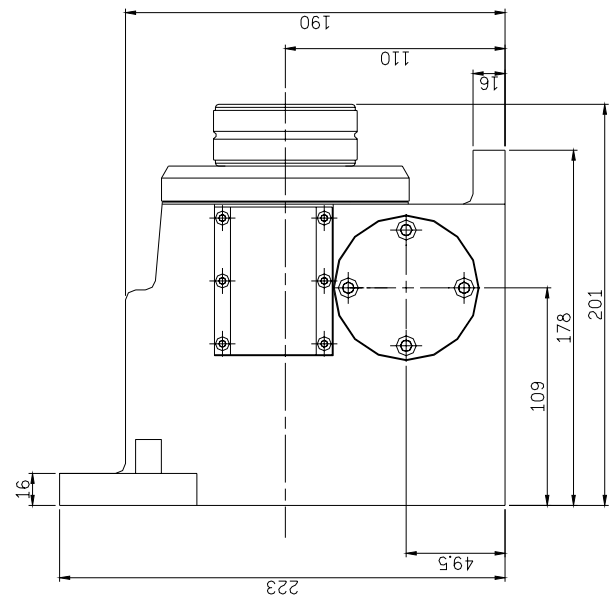
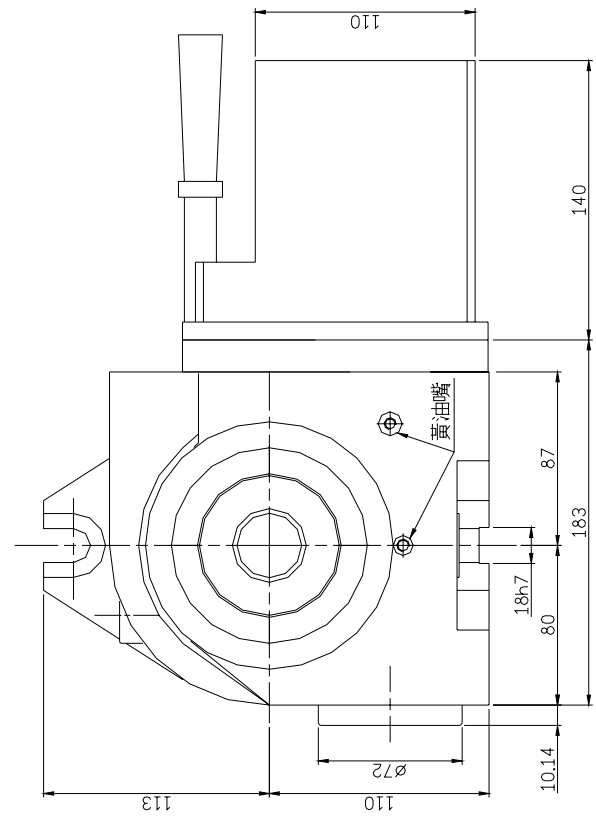
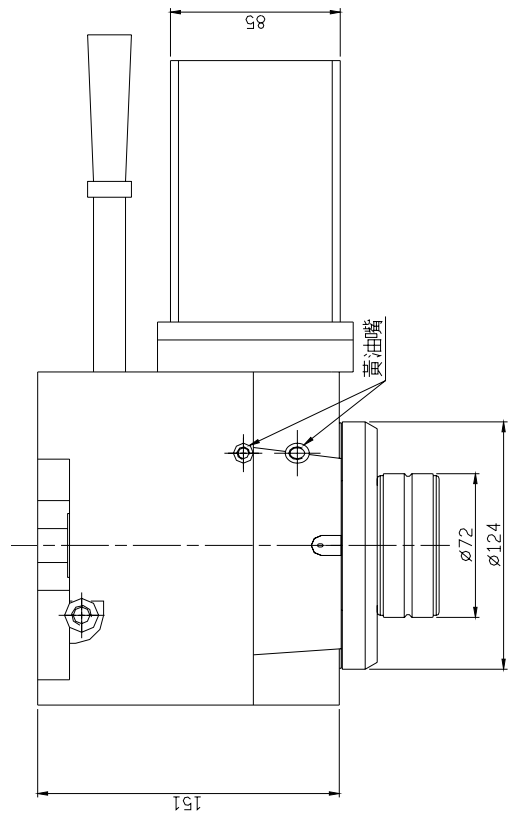

(3)INSPECTION REPORT

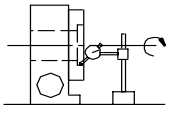
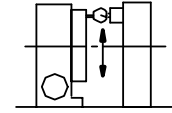
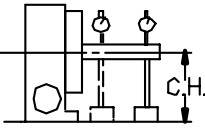
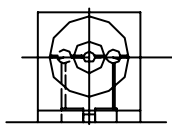
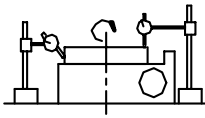
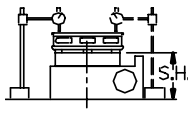
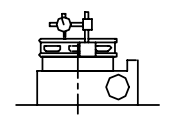
NO	MODEL		DMNC-5C	MEASURING
	INSPECTION ITEM			
1.	CENTERING CONCETRICITY	INLET SIDE	0.01	
2.	THE PERPENDICULARITY BETWEEN TABLE TOOP AND BOTTOM	LENGTH 300mm	0.02	
3.	PARALLELISM OF CENTER AXE AND LOWER	LENGTH 300mm	0.02	
4.	CENTER HEIGHT C.H		110	
5.	PARALELISM FOR CENTER SAXE OF THROUGH HOLE AND BASE SURFACE	LENGTH 300mm	0.02	
6.	DEVIATION FOR CENTER AXE OF THROUGHT HOLE AND BASE SURFACE	LENGTH 300mm	0.02	
7.	TABLE WARPING/ ROTATION	MAX. DIA.	0.02	
8.	PARALLELISM BETWEEN TABLE AND BOTTOM BASE	OVERALL LENGTH	0.02	
9.	TABLE HEIGHT FROM TABLE TOP TO BOTTOM BASE		155	
10.	FLATNESS OF UPPER SURFACE	OVERALL LENGTH	0.02	
11.	INDEXING ACCURACY	CUMULATED	60"	MEASURED BY OPTICAL DEVISION
12.	REPEATABILITY	CUMULATED	±2"	

(4) PREPARATION FOR OPERATION

4-1. LUBRICATION OIL

- (1) Select the lubricating oil of Z#, and fill in the lubrication oil in once every six months.

***** Recommended oil *****		
Jomo	-	Lathus 100 (or150)
Mobil	-	Gear 629
Shell	-	Omela Oil 100 (or150)
Esso	-	Spartan 100 (or 150)

- (2) Make sure to clean the area of oil inlet upon putting the oil in the unit, to avoid the dirt or chip get into the system. Once they get into, they will not only ruin the worm and wheel gear drive system, but also damage other mechanism in the short period of time.

(5) TRIAL RUNNING

After making sure the preparation, let's operate the rotary table with the following steps:

5-1 Before starting motor driving, check the following points:

- A. As it is important to make a trial running under free from the load, don't mount any work-pieces like jig, fixture or even chuck on the table surface.**
- B. Check the program whether N/C is providing the correct signals.**

5-2 Trial Running

- A. When rotating the table either clockwise or counterclockwise, start out slowly and then increase the speed (R.P.M.)**
- B. Give plenty of warm-up time, 20 to 30 minutes at the initial installation.**

5-3 Setting the distance of worm shift on zero-return with the zero return signal from N/C.

- A. The table returns to the origin very accurately in a fixed rotating direction...generally speaking in clockwise direction looking from the table with the following procedures :**
 - a. The table starts to rotate at the rapid feed.**
 - b. When it hits the dog, micro switch activates and slows down the speed on the level which can execute an accurate sudden stop and positioning at any time.**
 - c. After slowing down the speed, the signal from the motor detector stops the table at the position of origin.**

B. Zero-return mechanism is set to reduce the speed at just before the T-slot on the table in vertical position become parallel to the rotary table base.

C. Repeat the zero-return several times to check if it stops at position as programmed.

Note: Generally speaking, the zero-return is set at the Position where T-slot of the table becomes parallel to the base of the table becomes parallel to the base of rotary table. If there is any difference, that is the amount to be off-set in the N/C as the worm shaft of zero-return.

ZERO-RETURN INDICATING SKETCH

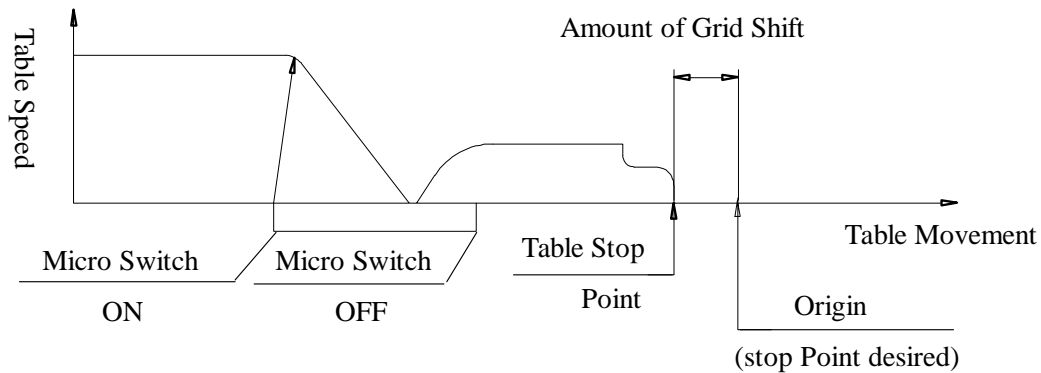

(6) WORK-PIECE MOUNTING

When mounting a work-piece on the rotary table, make sure the following points to avoid operator's accident, cutter or machine damages:

6-1 Check the table face whether any return, nick, dent, etc. Exist or not.

6-2 Avoid of mount the work-piece directly on the table which has poor flatness or perpendicularity. They may strain the table and prevent it from a smooth rotation, and which may result very poor indexing accuracy.

Note: Provide the maximum bearing surface to the work-piece by even shimming up if necessary.

6-3 If the work-piece is mounted on the rotary table at the off-centered position, it may cause inaccurate indexing.

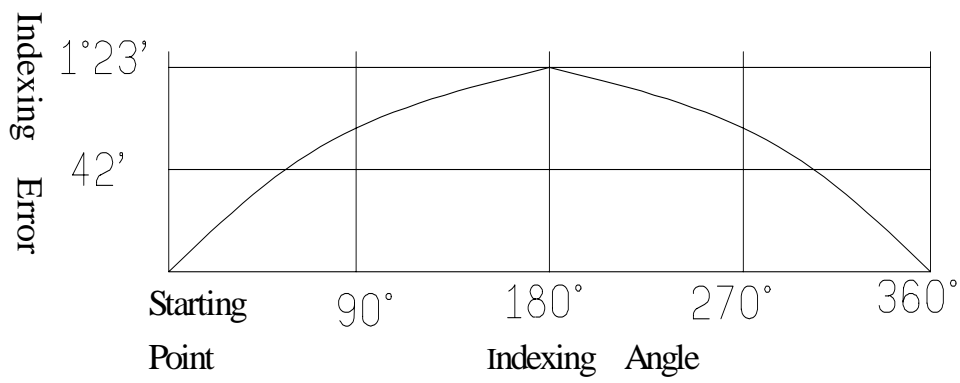
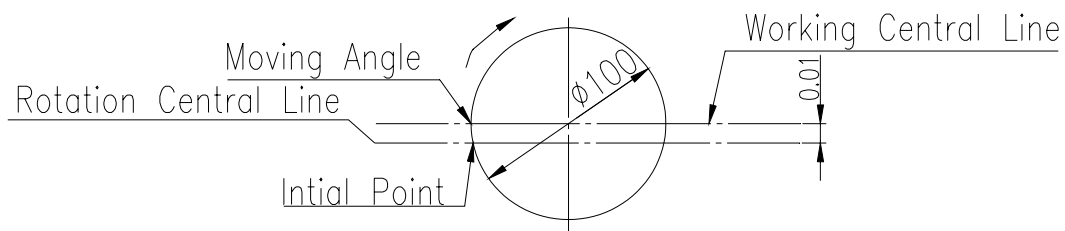

6-4 Location of work-piece clamping may be restricted depending upon

the shape of work-piece or cutting conditions, however, clamp down firmly on the surface of rotary table at the locations spaced out equally. The smaller the bearing surface may require for the more numbers of clamping to be stabilized the work-piece without straining the table.

Note: If it is a normal rotary table, you can feel whether the rotary table is strained or not due to uneven clamping of work-piece, however, when it comes to N/C rotary table, you just don't get that kind of feeling at all. Therefore, an extra caution must be taken for work-piece clamping.

(7) BACKLASH ADJUSTMENT OF WORM SHAFT

Too much of backlash means poor indexing accuracy and causes chattering in machining and poor finish. The best suitable backlash is around 0.003m/m—this already considered for the each gear movement and heat displacement in relation to the accuracy.

Note: When setting at smaller backlash than 0.002m/m, be sure to check

whether the rotary table can be rotated smoothly by Hand or not.

By the way, backlash of 0.008m/m at the tooth face means 0.01m/m at the position of table circumference. At the time of shipment from the factory, backlash is precisely adjusted, however, if necessary, you might be able to adjust it with following procedures:

7-1 Measuring the amount of Backlash

- A. Set a test indicator at the lock-nut by the circumference of the table as show below:

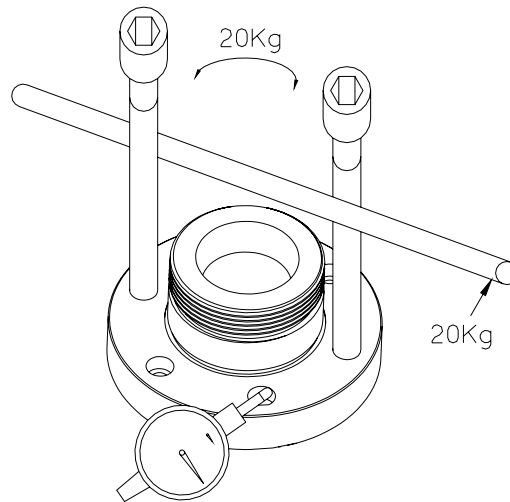

- B. Insert the steel plate into the T-Slot around 100m/m and move back and forth with approximately 20 kg force. With the force toward clockwise direction, the test indicator moves, and by releasing the force, it then returns to certain amount. However, this is not the backlash and caused an elastic force occurring at the worm gear and other parts involved. It is the same thing in counterclockwise direction. To obtain the exact amount of backlash, add up the indicator reading of the position after releasing the force both clockwise and

anti-clockwise direction. In other words, the total amount of indicator travel by force less indicator return after releasing the force is the amount of backlash. But, don't forget to check always both clockwise and counterclockwise direction.

Note: In case of adjusting the amount of backlash, an accurate amount of backlash can't be obtained if any play exists at the bearings which support the worm gear. Therefore, remove the worm gear cover shown at the next page and check the play and both O.D> and ace of (A) worm shaft with a test indicator at next page.

If any play, adjust by tightening the adjusting collar and then check the backlash again.

Note: After adjusted the backlash, make sure again to check the play existence at the face of (A).

C. After adjusted the backlash, if it is much more than 0.01m/m re-adjustment may be required for.

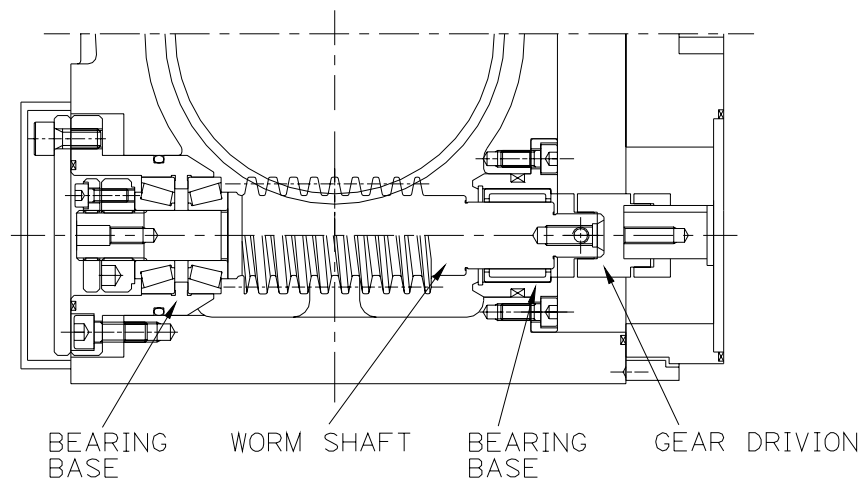

7-2 Adjusting the amount of backlash

A. Remove the cover.

- B. Equalize removing all 4 pieces of socket set screw. (Each socket set screw loosen anticlockwise around 1/3 of circle)
- C. Then remove 4 inner hexagon screws tighten in clockwise.
- D. Measuring the backlash to see if it is in the tolerate value. If not, please repeat the above instruction and adjust the backlash till tolerate value.

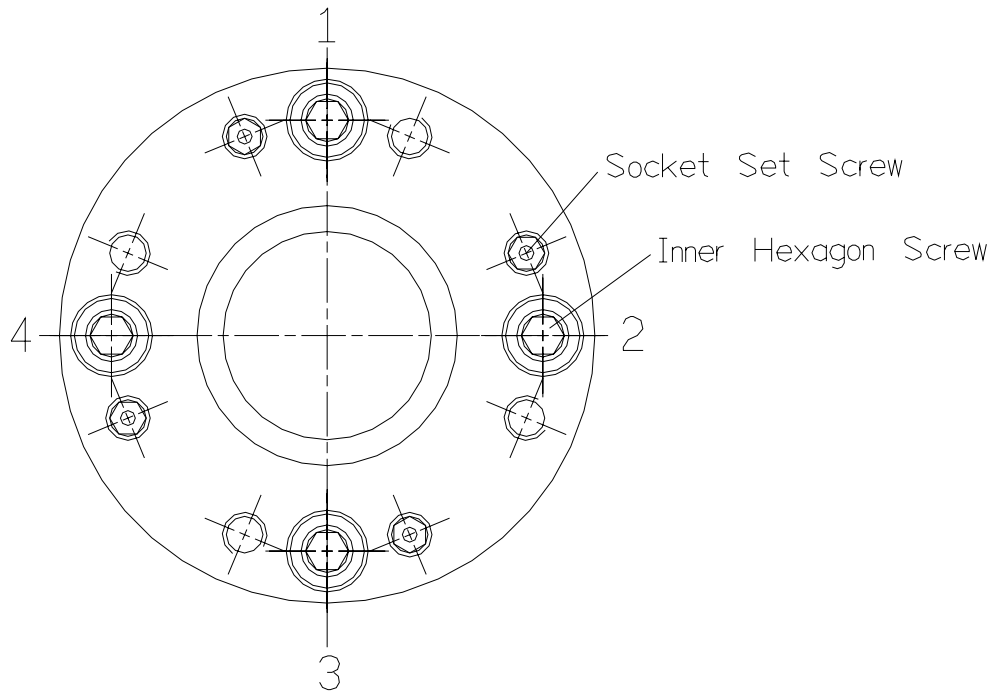
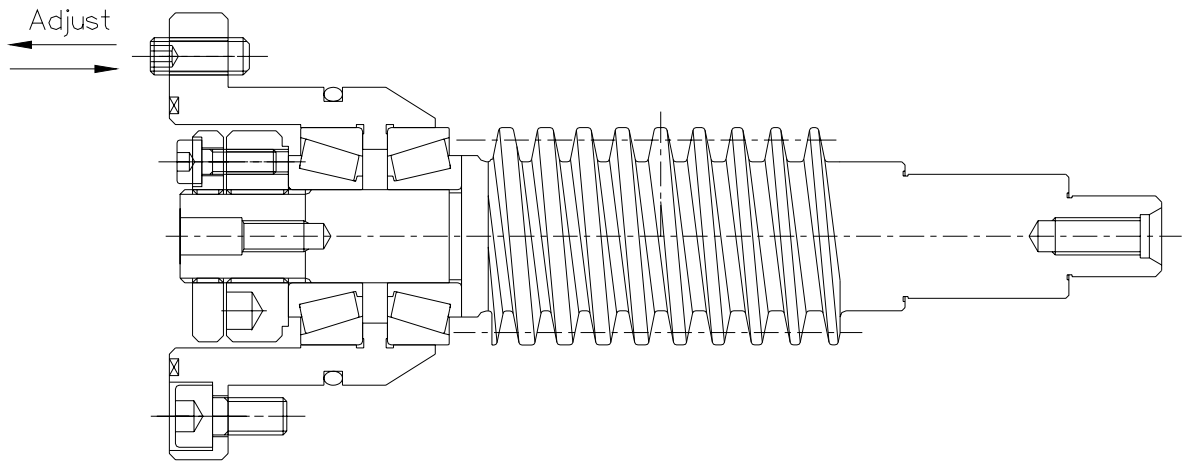

(8) Zero-Return setting and Dog adjusting

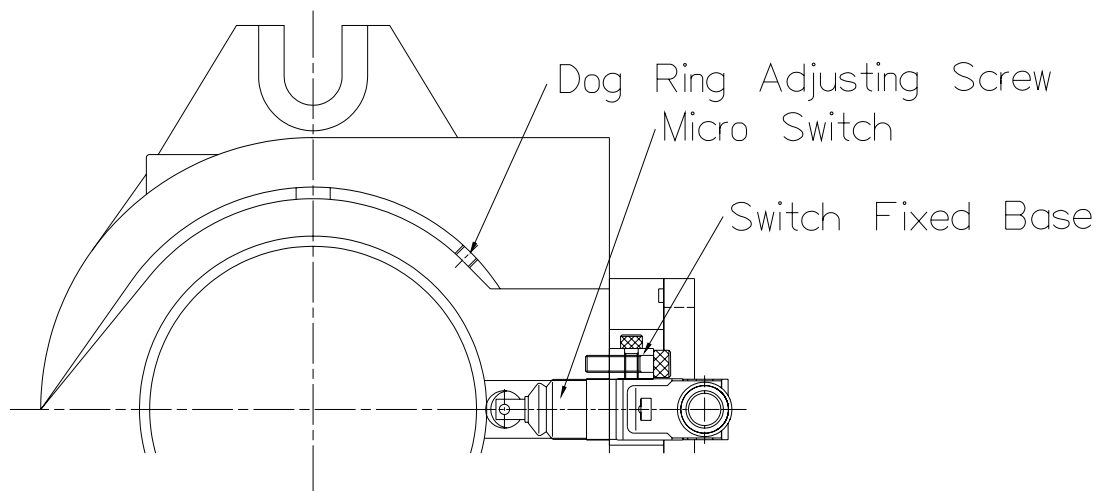

8-1 Zero-Return setting

To get the signal of speed down from the micro switch, when speed stopping, its meaning zero-position.

*** Adjusting the height of micro switch***

- a. Turning back to the home position by clockwise direction.
- b. The switch already set the travel stroke for the micro switch.
- c. When the switch fixed, please install the switch set into the body and test with the connect cable.

8-2 Adjusting Dog

- a. Loosen the screw bolt of the Dog, and through the window to confirm the dog position.
- b. To adjust the dog to the correct position by clockwise or counter clockwise direction.
- c. Through the parameter setting to get the dog zero-return.

(9) Maintenance and service

Check the following points Every Morning before operation.

- A. Check the oil level, No oil leakage?
- B. Check whether the rotary table is used within the capacities of load (work-piece weight) and cutting force (drive torque)
- C. Check the operation of clamp / unclamp.
- D. No particular noise in table rotation.

(10)EXPLODED VIEW

10-1

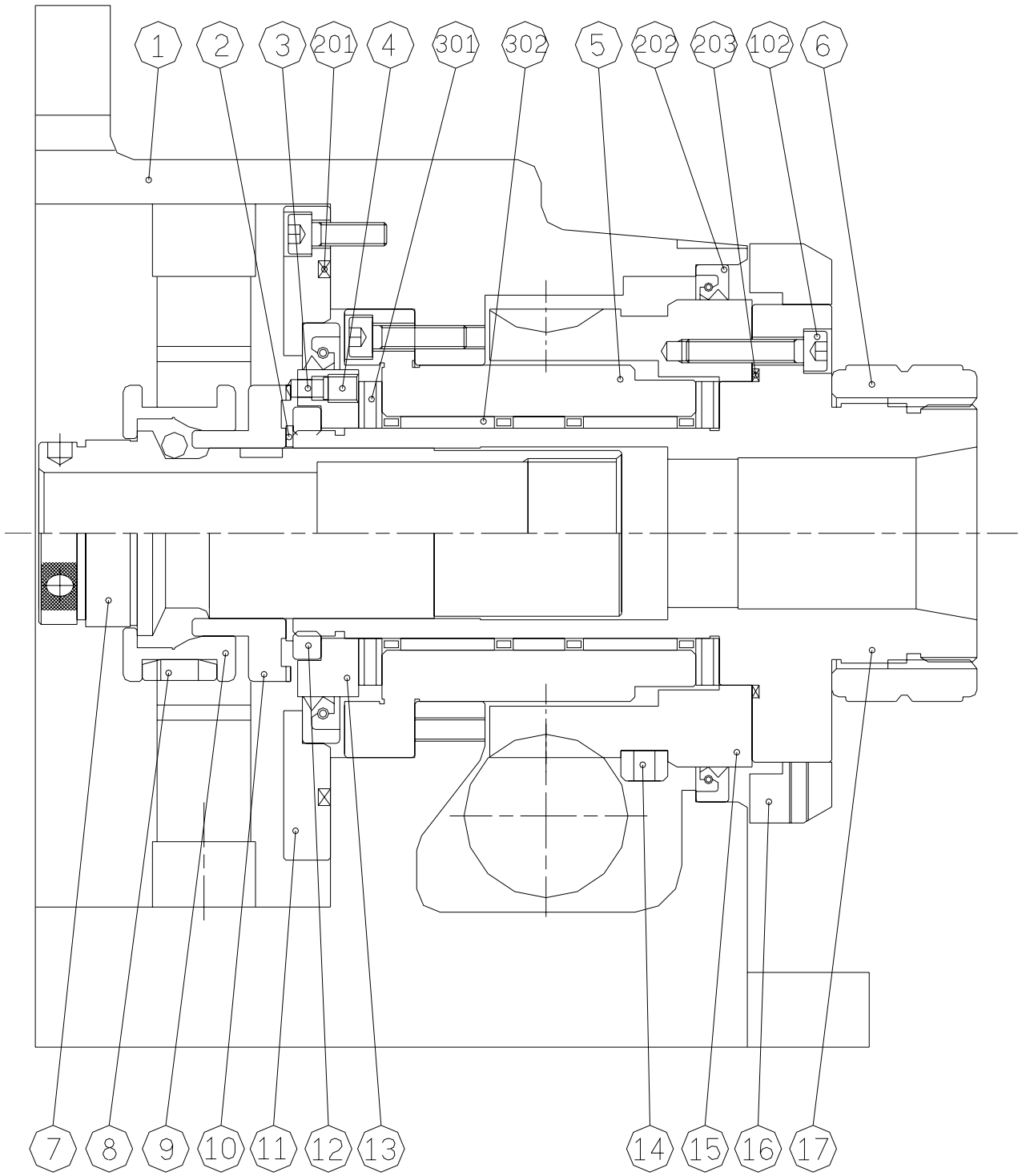

10-2

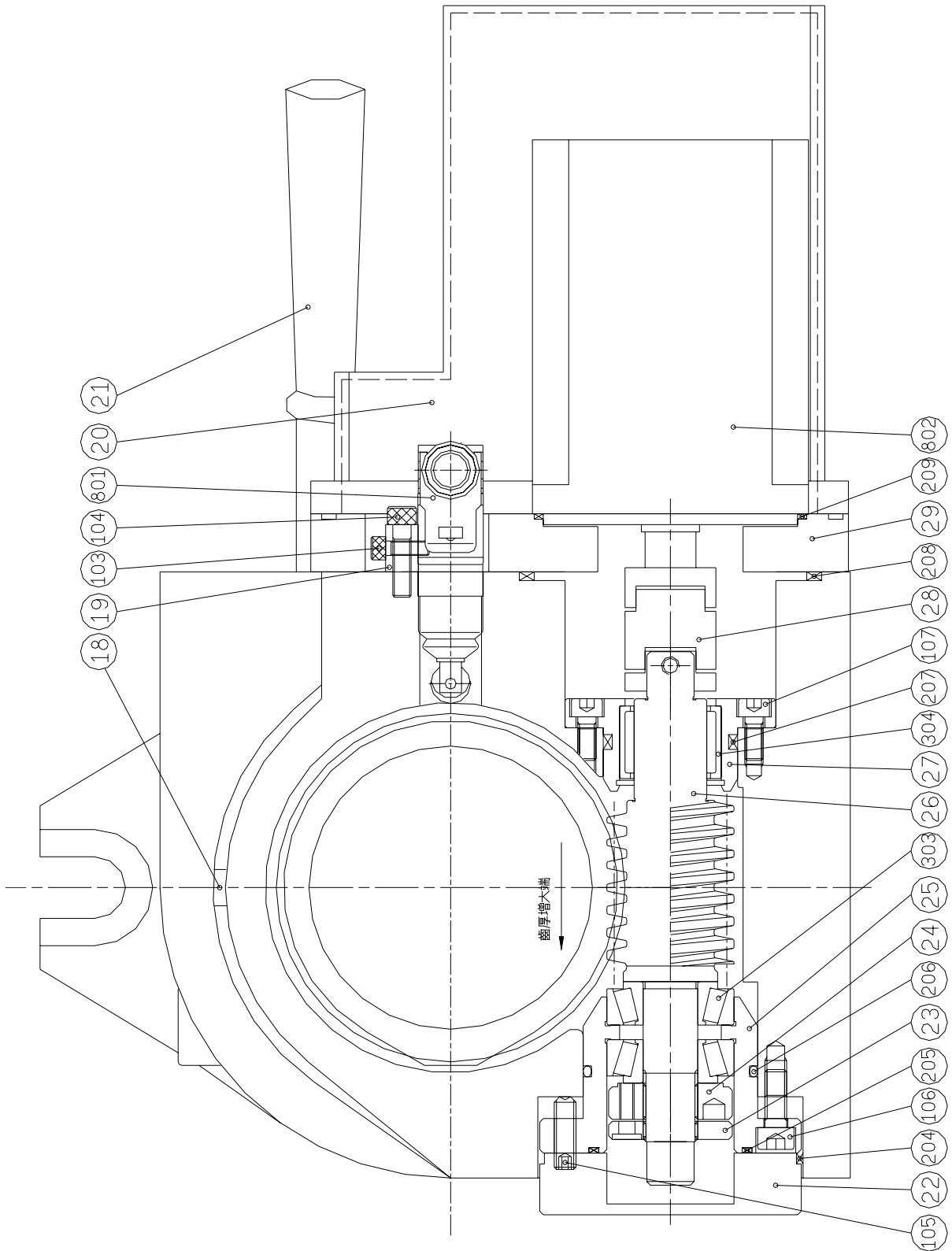

NO	PART NO.	ITEMS	SPEC.	Q'TY	REMARK
----	----------	-------	-------	------	--------

001	710401010	Body		1	
002	710402120	Draw Tube Packing		1	
003	710402090	Ratchet Pin		1	
004	710402070	Base of top needle		1	
005	710402050	Fixed Base		1	
006	710402030	Guide Ring		1	
007	710402200	Spindle		1	
008	710402140	Adjusting Ring		1	
009	710402150	Remove Base		1	
010	710402130	Stopping Ring		1	
011	710401050	Rear Cover		1	
012	710402100	O-ring		1	
013	710402110	Fixed Key		1	
014	710402060	Sensor Ring		1	
015	710402040	Worm Wheel		1	
016	710402210	Indicate Cover		1	
017	710402010	Spindle		1	
018	710401030	Indicating Plate		1	
019	160401030	Micro Base		1	
020	710405010	Motor Cover		1	
021	710408010	Draw Handle		1	
022	710403010	Side Cover		1	
023	170103040	Fixed Screw Ring		1	
024	170103050	O-Ring		1	
025	170103030	Left Fixed Bearing Base		1	
026	710403040	Worm Shaft		1	
027	170103020	Right Fixed Bearing Base		1	
028	170108070	Coupling		1	
029	710408020	Motor Cover		1	
101		Inner Hexagon Screw	M5×16L	6	
102		Inner Hexagon Screw	M5×20L	1	
103		Inner Hexagon Screw	M4×12L	1	
104		Inner Hexagon Screw	M5×20L	1	

