

**OPERATION
MANUAL**

CNC ROTARY TABLE

MODEL: DMNC-5CA

YUASA INTERNATIONAL.

INDEX

DESCRIPTION

PAGE

| | |
|-----------------------------------|---|
| (1)SPECIFICATION | 2 |
| (2)OUTSIDE DIMENSION LAYOUT | |
| 3 | |
| (3)INSPECTION REPORT | |
| 4 | |
| (4)PREPARATION FOR OPERATION | |
| 5 | |
| 4-1.LUBRICATING OIL | 5 |
| 4-2.PNEUMATIC FOR TABLE CLAMPING | |
| 5 | |
| (5)TRIAL RUNNING | |
| 6 | |
| 5-1.PREPARATION FOR MOTOR DRIVING | |
| 6 | |
| 5-2.TRIAL RUNNING | |
| 6 | |
| 5-3.DISTANCE SETTING OF SPINDLE | |

6

(6)WORK-PIECE MOUNTING

7

(7)BACKLASH ADJUSTMET FOR
WORM SHAFT & WHEEL

9

7-1.MEASUREMENT OF BACKLASH

9

7-2.VALVE OF BACKLASH ADJUSTING

11

(8)STRUCTION OF ZERO-RETURN

12

8-1.ZERO-RETURN

12

8-2.ADJUSTMENT OF DOG

12

(9)MAINTAINANCE AND SERVICE

12

(10)EXPLODED VIEW & PART LIST

13

(1) SPECIFICATION

| | ITEM | UNIT | DMNC-5CA | REMARK |
|-----|--------------------------|--------|-------------|----------------------------------|
| 1. | CENTER HIGH IN VERTICAL | mm | 130 | |
| 2. | OVERALL HIGH IN VERTICAL | mm | 210 | |
| 3. | OVERALL LENGTH | mm | 316 | P5 |
| 4. | | mm | 358 | α 2i |
| 5. | OVERALL WIDTH | mm | 155 | |
| 6. | WIDTH FOR GUIDE BLOCK | mm | 18h7 | |
| 7. | WIDTH FOR T-SLOT | mm | 12h7 | |
| 8. | SERVO MOTOR | SANYO | P50B07030 | |
| | | FANUC | α 2i | |
| 9. | GEAR RATIO | | 1:45 | |
| 10. | MAX. INDEXING | DEGREE | 0.001 | |
| 11. | MAX. SPEED FOR ROTATING | r.p.m. | 44.4 | 2000r.p.m |
| 12. | MAX. MACHINE FORCE | kg-m | 20 | |
| 13. | POSITIONING ACCURACY | sec | 60 | |
| 14. | REPEATABILITY | sec | \pm 3 | |
| 15. | MAX. BRAKING TORQUE | Kg-m | 7 | Pneumatic 6kg/cm ² |
| 16. | NET WEIGHT | kg | 28 | |

(2) OUTSIDE DIMENSION LAYOUT

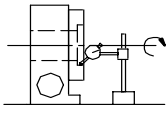
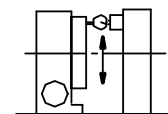
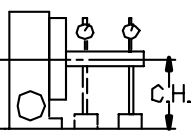
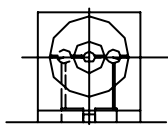
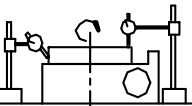
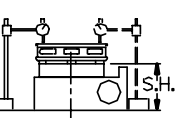
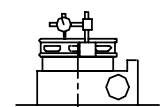
| NO | INSPECTION ITEM | MODEL | DMNC-5C A | MEASURING |
|-----|---|-----------------|--------------|---|
| 1. | CENTERING CONCETRICITY | INLET SIDE | 0.01 |  |
| 2. | THE PERPENDICULARITY BETWEEN TABLE TOOP AND BOTTOM | LENGTH 300mm | 0.02 |  |
| 3. | PARALLELISM OF CENTER AXE AND LOWER | LENGTH 300mm | 0.02 |  |
| 4. | CENTER HEIGHT C.H | | 130 | |
| 5. | PARALELISM FOR CENTER SAXE OF THROUGH HOLE AND BASE SURFACE | LENGTH 300mm | 0.02 |  |
| 6. | DEVIATION FOR CENTER AXE OF THROUGH HOLE AND BASE SURFACE | LENGTH 300mm | 0.02 | |
| 7. | TABLE WARPING/ ROTATION | MAX. DIA. | 0.02 |  |
| 8. | PARALLELISM BETWEEN TABLE AND BOTTOM BASE | OVERALL LENGTH | 0.02 |  |
| 9. | TABLE HEIGHT FROM TABLE TOP TO BOTTOM BASE | | 206 | |
| 10. | FLATNESS OF UPPER SURFACE | OVERALL LENGTH | 0.02 |  |
| 11. | INDEXING ACCURACY | CUMULATED | 60" | MEASURED BY OPTICAL DEVISION |
| 12. | REPEATABILITY | CUMULATED | ±3" | |

(4) PREPARATION FOR OPERATION

4-1. LUBRICATION OIL

- (1) Select the lubricating oil which has the features such as strong oil film, strong rust proof and good stability of oxidation.

Also viscosity grade should be around ISO, VG100-150. Since the same oil circulates among worm, wheel and other mechanical parts, purchase quality oil so that the unit can operate in good condition for many years to come.

******* Recommended oil *******

Jomo - Lathus 100 (or150)

Mobil - Gear 627

Shell - Omela Oil 100 (or150)

Esso - Spartan 100 (or 150)

- (2) When putting the oil in the unit, make sure to clean the area of oil inlet so that dirt or chip won't get into the system. Once they get into, they will, not only ruin the worm and wheel gear drive system, but also damage other mechanism in the short period of time.

- (3) Put the oil slowly up to the center line of the gage. The amount of oil you are putting in is very important, and make sure to put neither too much nor too little. When checking the oil level, check approximately 30 minutes after stopped the operation.

(4) Change the entire oil with fresh one in once every six months.

When draining the oil completely, set the unit in horizontal position to enable easy draining from the unit

4-2. Pneumatic For Table Clamping

Connect the hose with hydraulic inlet and supply the pressurized oil.

Although clamping mechanism is designed to stand for max. 70 kg/cm of hydraulic pressure, 50kg/cm is, however, plenty good to obtain the sufficient clamping force. The relationship between hydraulic pressure and clamping force is shown below and select the proper hydraulic pressure to your need.

Note: Apply a quality hydraulic nose to sustain the pressure well. (5)

TRIAL RUNNING

After making sure the preparation, let's operate the rotary table with the following steps:

5-1 Before starting motor driving, check the following points:

- A. As it is important to make a trial running under free from the load, don't mount any work-pieces like jig, fixture or even chuck on the table surface.
- B. Check the program whether N/C is providing the correct signals.

5-2 Trial Running

- A. When rotating the table either clockwise or counterclockwise, start

out slowly and then increase the speed (R.P.M.)

- B. Give plenty of warm-up time, 20 to 30 minutes at the initial installation.

5-3 setting the distance of worm shift on zero-return with the zero returns signals from N/C.

- A. The table returns to the origin very accurately in a fixed rotating direction...generally speaking in clockwise direction looking from the table with the following procedures :
 - a. The table starts to rotate at the rapid feed.
 - b. When it hits the dog, micro switch activates and slows down the speed on the level which can execute an accurate sudden stop and positioning at any time.
 - c. After slowing down the speed, the signal from the motor detector stops the table at the position of origin.
- B. Zero-return mechanism is set to reduce the speed at just before the T-slot on the table in vertical position become parallel to the rotary table base.
- C. Repeat the zero-return several times to check if it stops at position as programmed.

ZERO-RETURN INDICATING SKETCH

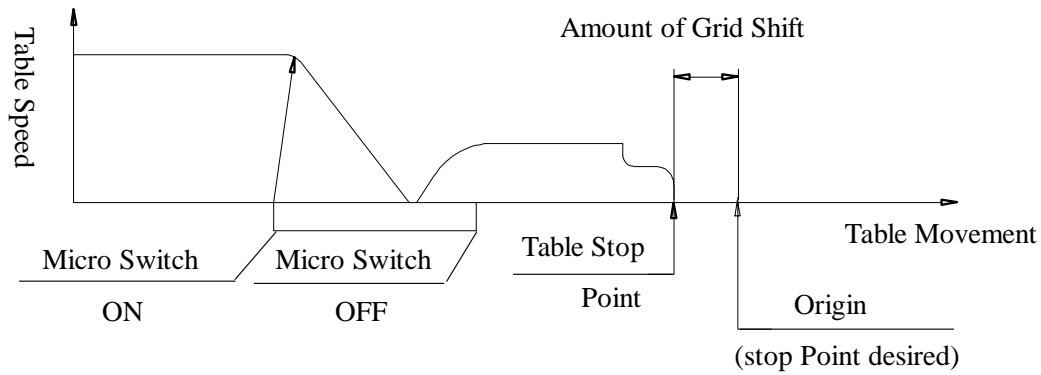

(6) WORK-PIECE MOUNTING

When mounting a work-piece on the rotary table, make sure the following points to avoid operator's accident, cutter or machine damages:

6-1 Check the table face whether any return, nick, dent, etc. Exist or not.

6-2 Avoid the mounting of a work-piece directly on the table which has poor flatness or perpendicularity. They may strain the table and prevent it from a smooth rotation, and which may result very poor indexing accuracy.

Note: Provide the maximum bearing surface to the work-piece by even shimming up if necessary.

6-3 If the work-piece is mounted on the rotary table at the off-centered position, it may cause inaccurate indexing.

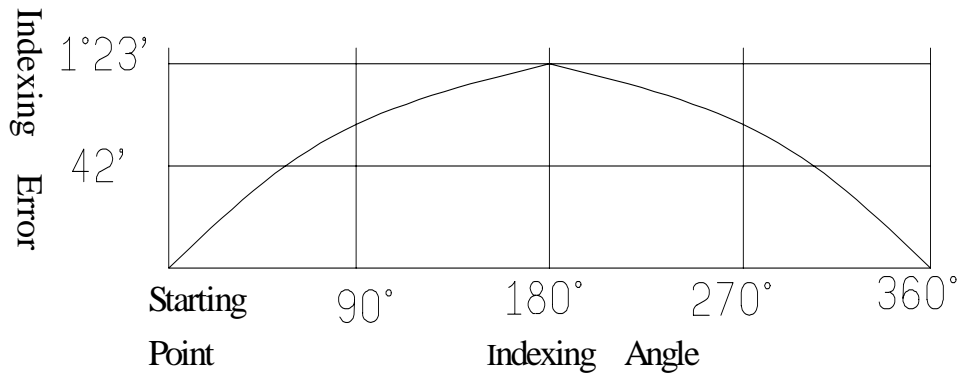
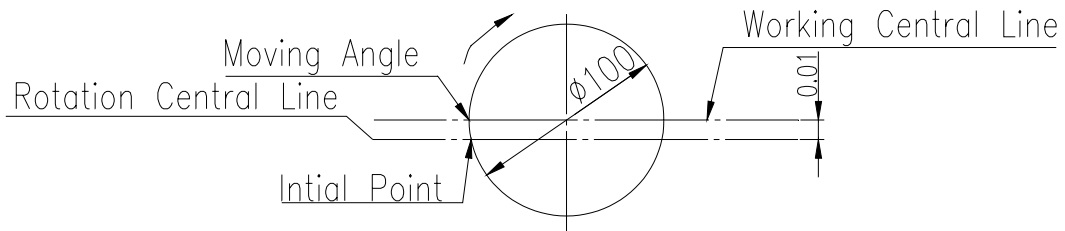

6-4 Location of work-piece clamping may be restricted depending upon the shape of work-piece or cutting conditions, however, clamp down firmly on the surface of rotary table at the locations spaced out equally. The smaller the bearing surface may require for the more numbers of clamping to be stabilized the work-piece without straining the table.

Note: If it is a normal rotary table, you can feel whether the rotary table is strained or not due to uneven clamping of work-piece, however, when it comes to N/C rotary table, you just don't get that kind of feeling at all. Therefore, an extra caution must be taken for work-piece clamping.

(7) BACKLASH ADJUSTMENT OF WORM SHAFT

Too much of backlash means poor indexing accuracy and causes chattering in machining and poor finish. The best suitable backlash is around 0.008m/m—this already considered for the each gear movement and heat displacement in relation to the accuracy.

Note: When setting at smaller backlash than 0.01m/m, be sure to check whether the rotary table can be rotated smoothly by Hand or not.

By the way, backlash of 0.008m/m at the tooth face means 0.01m/m at the position of table circumference. At the time of shipment from the factory, backlash is precisely adjusted, however, if necessary, you might be able to adjust it with following procedures:

7-1 measuring the amount of Backlash

- A. Set a test indicator at the lock-nut by the circumference of the table as show below:**

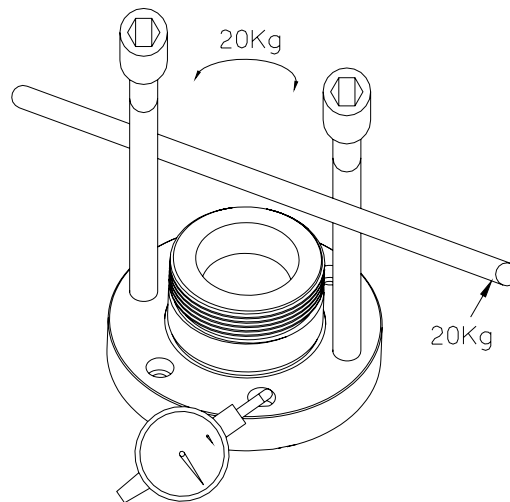

B. Insert the steel plate into the T-Slot around 100m/m and move back and forth with approximately 20 kg force. With the force toward clockwise direction, the test indicator moves, and by releasing the force, it then returns to certain amount. However, this is not the backlash and caused an elastic force occurring gat the worm gear and other parts involved. It is the same thing in counterclockwise direction. To obtain the exact amount of backlash, add up the indicator reading of the position after releasing the force both clockwise and anti-clockwise direction. In other words, the total amount of indicator travel by force less indicator return after releasing the force is the amount of backlash. But, don't forget to check always both clockwise and counterclockwise direction.

Note: In case of adjusting the amount of backlash, an accurate amount of backlash can't be obtained if any play exists at the bearings which support the worm gear. Therefore, remove the worm gear cover shown at the next page and check the play and both O.D> and ace of (A) worm shaft with a test indicator at next page. If any play, adjust by tightening the adjusting collar and then check the backlash again.

Note: After adjusted the backlash, make sure again to check the play existence at the face of (A).

C. After adjusted the backlash, if it is much more than 0.01m/m re-adjustment may be required for.

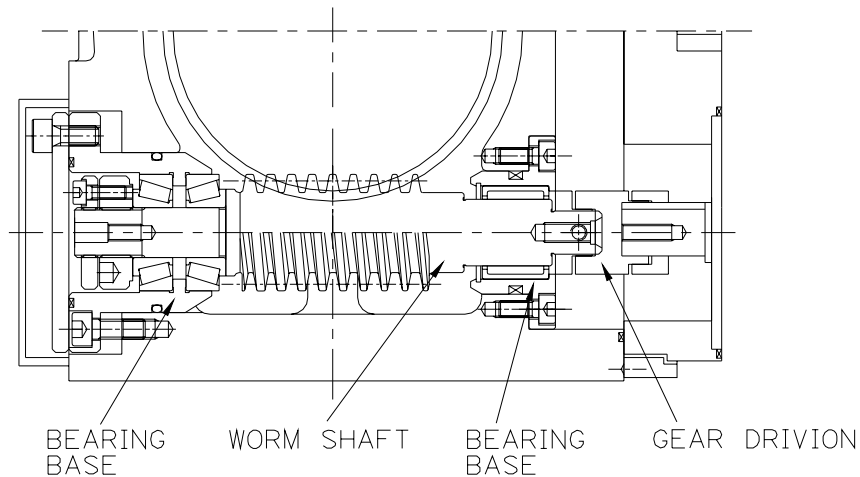

7-2 adjusting the amount of backlash

- A.** Remove the cover.
- B.** Equalize removing all 4 pieces of socket set screw. (Each socket set screw loosen anticlockwise around 1/3 of circle)
- C.** Then remove 4 inner hexagon screws tighten in clockwise.
- D.** Measuring the backlash to see if it is in the tolerate value. If not, please repeat the above instruction and adjust the backlash till tolerate value.

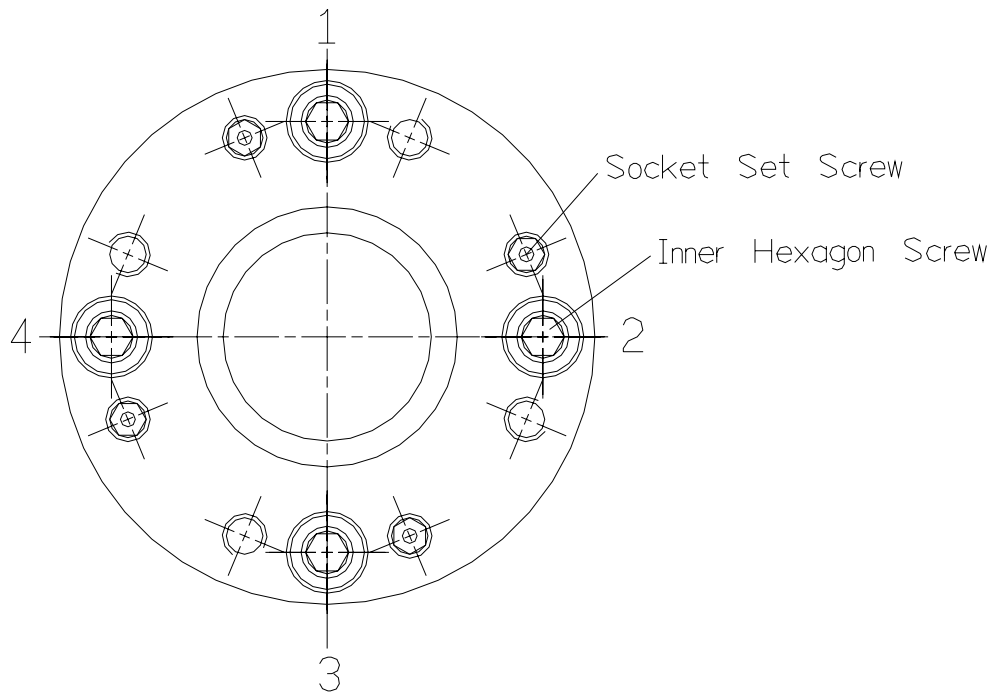
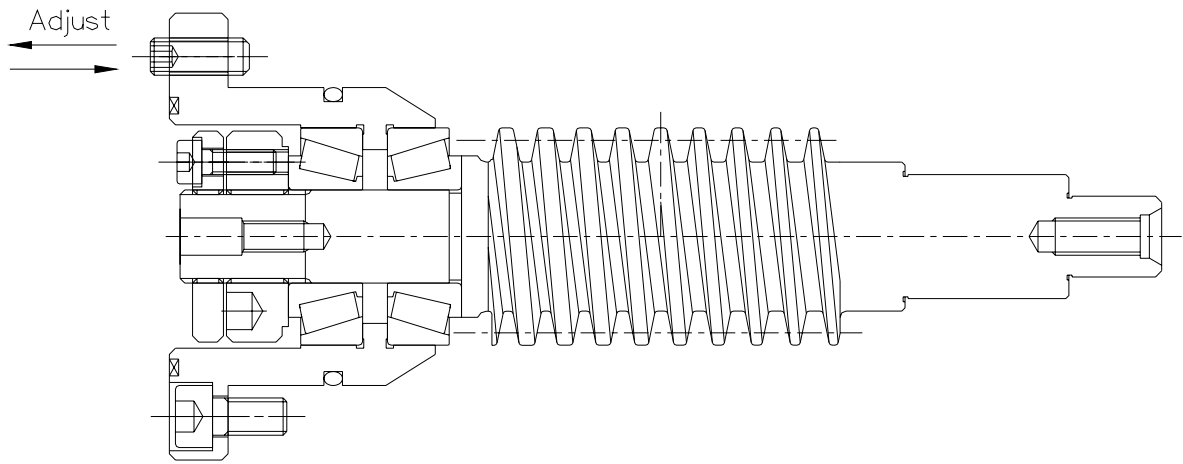

(8) Zero-Return setting and Dog adjusting

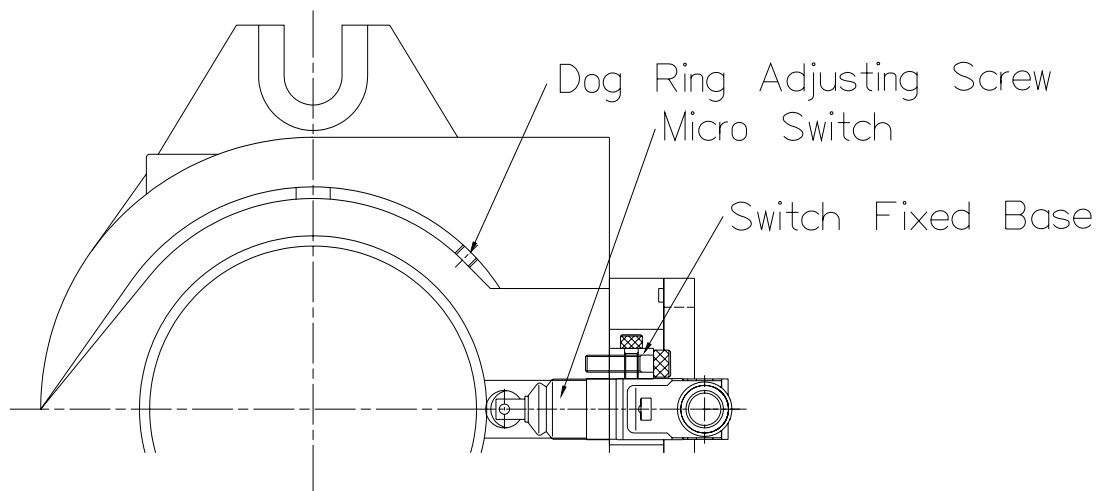

8-1 Zero-Return setting

To get the signal of speed down from the micro switch, when speed stopping, its meaning zero-position.

*** Adjusting the height of micro switch***

- a. Turning back to the home position by clockwise direction.
- b. The switch already set the travel stroke for the micro switch.
- c. When the switch fixed, please install the switch set into the body and test with the connect cable.

8-2 Adjusting Dog

- a. Loosen the screw bolt of the Dog, and through the window to confirm the dog position.
- b. To adjust the dog to the correct position by clockwise or counter clockwise direction.
- c. Through the parameter setting to get the dog zero-return.

(9) Maintenance and service

Check the following points Every Morning before operation.

- A. Check the oil level, No oil leakage?

B. Check whether the rotary table is used within the capacities of load (work-piece weight) and cutting force (drive torque)

C. Check the operation of clamp / unclamp.

D. No particular noise in table rotation.

(10)EXPLODED VIEW

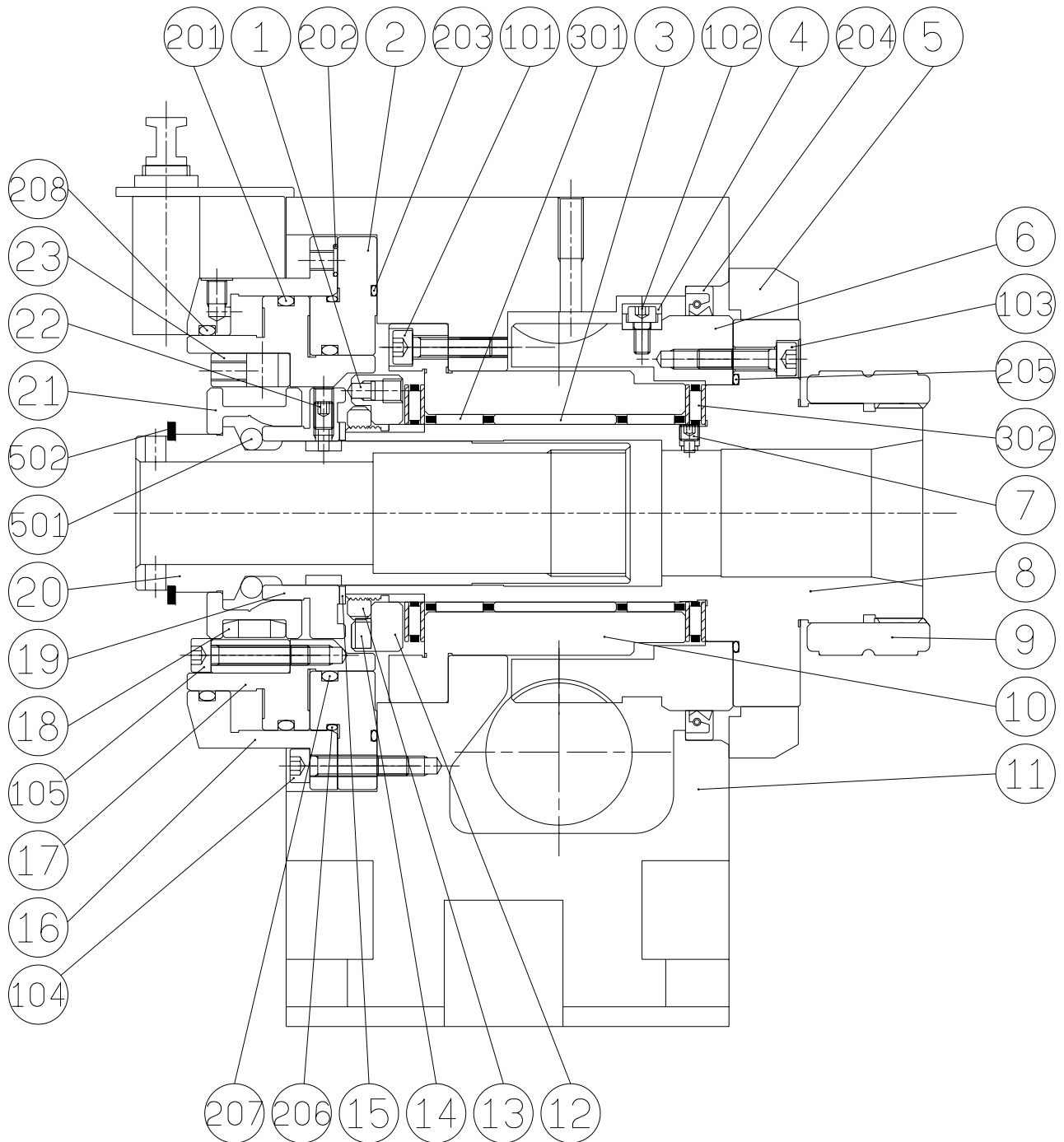

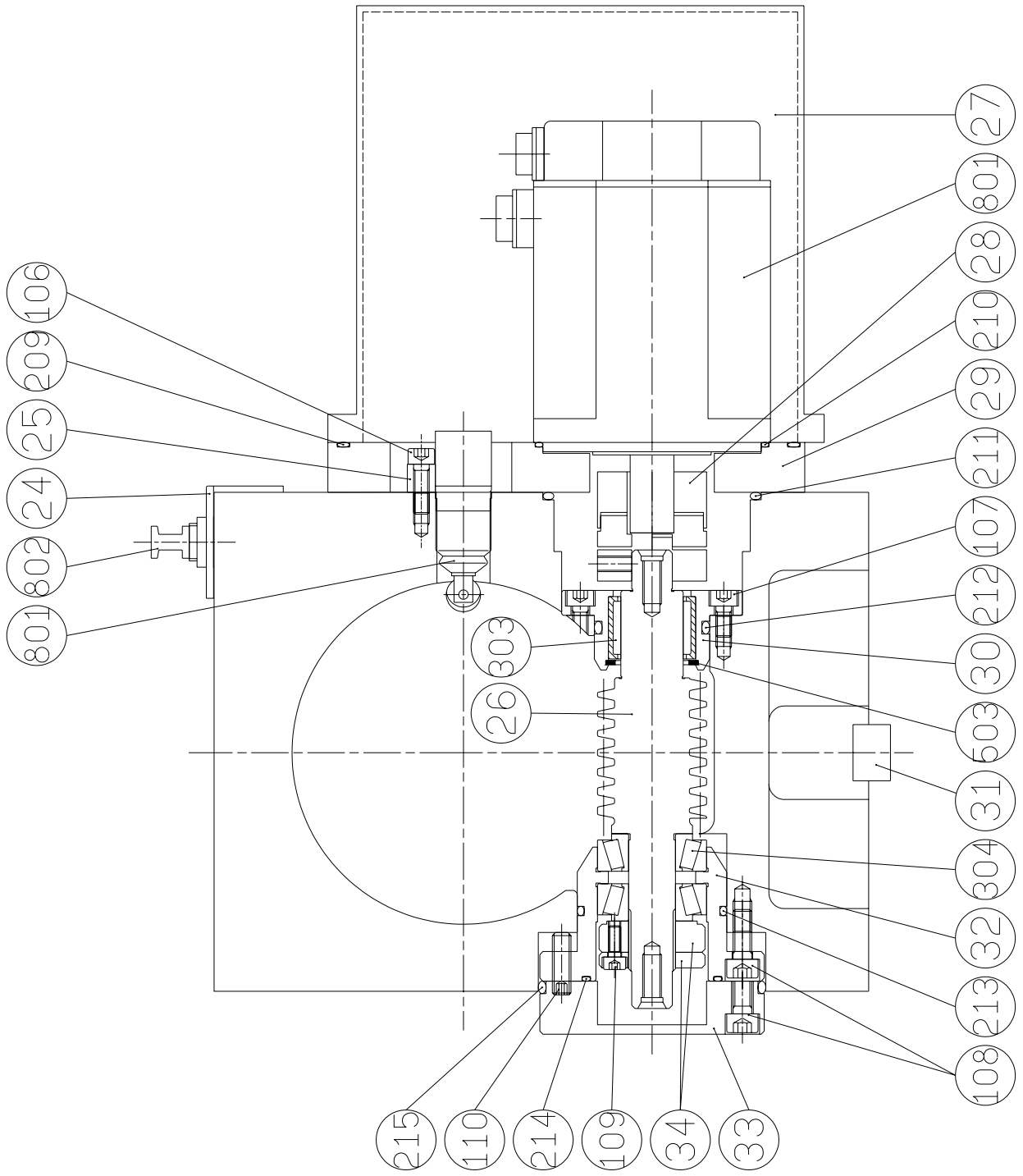

| No. | Serial No. | Description | Specification | Q'ty | Remark |
|-----|------------|--------------------------|---------------|------|--------|
| 1. | 710402090 | Top Roller | Ø4.76×6L | 1 | |
| 2. | 710402180 | Cylinder Base | Ø140×17L | 1 | |
| 3. | 710408130 | Roller Fixed Ring | Ø50×31L | 1 | |
| 4. | 710402060 | Sensor Ring | Ø105×10L | 1 | |
| 5. | 710402211 | Draw Ring | Ø124×17.5L | 1 | |
| 6. | 710402040 | Worm Wheel | Ø100×56L | 1 | |
| 7. | 710100260 | Locked Screw Bolt | Ø5×7L | 1 | |
| 8. | 710402011 | Spindle | Ø98×146L | 1 | |
| 9. | 710402030 | Guide Ring | Ø72×31L | 1 | |
| 10. | 710402050 | Fixed Base | Ø96×75L | 1 | |
| 11. | 710401040 | Body | | 1 | |
| 12. | 710402071 | Top Roller Base | Ø70×13L | 1 | |
| 13. | 710402100 | Against Ring | Ø54×6L | 1 | |
| 14. | 710402110 | Fixed Key | 7.5×6.35L | 1 | |
| 15. | 710402120 | Braking Pad | t=1.5mm | 1 | |
| 16. | 710402170 | Cylinder | Ø110×47.5L | 1 | |
| 17. | 710402190 | Cylinder Cover | Ø140×38L | 1 | |
| 18. | 710402140 | Adjusting Ring | Ø15.9×4.5L | 2 | |
| 19. | 710402130 | Topping Ring | Ø63.5×21L | 1 | |
| 20. | 710402200 | Spindle | Ø43.8×125L | 1 | |
| 21. | 710402150 | Movement Base | Ø63.5×24L | 1 | |
| 22. | 710402230 | Locked Screw Bolt | Ø5×12.5L | 1 | |
| 23. | 710402160 | Fixed Ring | Ø81×20L | 1 | |
| 24. | 710401020 | Switch Base | t=2mm | 1 | |
| 25. | 170401062 | Micro-Switch Base | KEY9×9×45L | 1 | |
| 26. | 710403040 | Worm Shaft | Ø35×147L | 1 | |
| 27. | 710405030 | Motor Cover | | 1 | P5 |
| | 710405051 | Motor Cover | | 1 | α2i |
| 28. | 710403050 | Coupling | MCZ35(13×16c) | 1 | P5 |
| | 710403061 | Coupling | MCZ35(13×19c) | 1 | α2i |
| 29. | 710408030 | Motor Flange | t=16mm | 1 | P5 |
| | 710408060 | Motor Flange | t=21mm | 1 | α2i |
| 30. | 170103020 | Right Fixed Bearing Base | Ø58×25.5L | 1 | |

| No. | Serial No. | Description | Specification | Q'ty | Remark |
|------|--------------------------|--|-------------------|--------|--------|
| 31. | 110301030 | Guide Key | 20×18×12L | 2 | |
| 32. | 170103030 | Left Fixed Bearing Base | Ø72×43L | 1 | |
| 33. | 710403010 | Side Cover | Ø72×17L | 1 | |
| 34. | 170103040 170103050 | Fixed Screw Against Ring | Ø34×5L Ø34×10L | 1 1 | |
| 101. | B301-A5*20 | Inner Hexagon Screw | M5×20L | 8 | |
| 102. | B301-A4*8 | Inner Hexagon Screw | M4×8L | 2 | |
| 103. | B301-A5*20 | Inner Hexagon Screw | M5×20L | 6 | |
| 104. | B301-A5*25 | Inner Hexagon Screw | M5×25L | 6 | |
| 105. | B301-A5*25 | Inner Hexagon Screw | M5×25L | 4 | |
| 106. | B301-A5*16 | Inner Hexagon Screw | M5×16L | 2 | |
| 107. | B301-A6*10 | Inner Hexagon Screw | M6×10L | 6 | |
| 108. | B301-A6*16 B301-A6*20 | Inner Hexagon Screw Inner Hexagon Screw | M6×16L M6×20L | 4 4 | |
| 109. | B301-A4*10 | Inner Hexagon Screw | M4×10L | 4 | |
| 110. | B301-T6*20 | Stopping Screw | M6×20L | 4 | |
| 201. | B2G105 | O-Ring | G105 | 1 | |
| 202. | B2P6 | O-Ring | P6 | 1 | |
| 203. | B2S110 | O-Ring | S110 | 1 | |
| 204. | B2TC1001157 | TC Oil Seal | TC1001157 | 1 | |
| 205. | B2S65 | O-Ring | S65 | 1 | |
| 206. | B2S110 | O-Ring | S110 | 1 | |
| 207. | B2G80 | O-Ring | G80 | 1 | |
| 208. | B2G90 | O-Ring | G90 | 1 | |
| 209. | B2S145 | O-Ring | S145 | 1 | |
| 210. | B2S70 | O-Ring | S70 | 1 | |
| 211. | B2G65 | O-Ring | G65 | 1 | |
| 212. | B2G30 | O-Ring | G30 | 1 | |
| 213. | B2S40 | O-Ring | S40 | 1 | |
| 214. | B2S40 | O-Ring | S40 | 1 | |
| 215. | B2G65 | O-Ring | G65 | 1 | |
| 301. | B1-K455017 | Bearing | K455017 | 2 | |
| 302. | B1-NTB4565 B1-AS4565 | Bearing Pad | NTB4565 AS4565 | 2 4 | |

| No. | Serial No. | Description | Specification | Q'ty | Remark |
|------|---------------|-----------------|---------------|------|----------|
| 303. | B1-TAF202820 | Bearing | TAF202820 | 1 | |
| 304. | B1-30202 | Bearing | 30202 | 2 | |
| 501. | B314-5.5 | Steel Ball | Ø5.5 | 21 | |
| 502. | B301-C40B | C Type Ring | Outer Ø40 | 1 | |
| 503. | B301-C28A | C Type Ring | Inner Ø28 | 1 | |
| 801. | E100-D4E1E20N | Micro Switch | D4E-1E20N | 1 | |
| 802. | E800-4PPX | Manual Draw Bar | 4PPX | 1 | |
| 803. | | Servo Motor | P50B07030 | 1 | Optional |
| | | Servo Motor | α2i | 1 | Optional |